

Precautions

⚠ CAUTION

- Ensure to read and follow instructions of operation manual when handling the actuator introduced in this catalog.
- Handle the product carefully so that it may not fall or drop on the ground. Any extraordinary mechanical impact should be avoided.
- Indoor storage of the product in a dust-free, low humidity and well-ventilated place is recommended.
- DO NOT remove protective cover until installation.
- DO NOT apply excessive load or step on the product, which may damage the product or cause personal injury.
- Allow sufficient room for manual operation or the removal of the actuator cover, when the valve is installed in the pipeline.
- Where the actuator is exposed to sunlight or rainwater while in service, use appropriate protection for trouble-free operation. Also use insulation boards for heat generated from the equipment around the actuator.
- Take some appropriate measures, if the possibilities of damage by briny atmosphere, snow or freezing are expected.
- Avoid installing the valve where the actuator may be hampered by vibration caused by equipment such as pumps or engines.
- Before installation, the connecting pipes should be cleaned to remove any foreign objects such as sand, dust or welding spatters.
- When threaded valves are screwed into pipes, apply a spanner to the ends of valves on the side of the connecting pipe being inserted.
- For flanged valves, alternately tighten bolts of the end flanges in a star pattern to ensure to fasten the flanges properly.
- The actuator should not be mounted downward in any piping orientation.
- The pipeline should be flushed to remove foreign particles from pipes.
- If cast iron or cast carbon steel valves are used in the water line, be aware that rust may develop in the valves, which may damage the ball seats, leading to operation failure. Pay extra attention on valve selection and protection from rust.
- Connect cables correctly in accordance with the circuit diagram.
- Ensure to use a terminal base when connecting cables.
- After connecting cables, conduct an insulation resistance test to ensure its insulation.
- Ensure the housing is securely sealed with such sealing materials as O-rings to prevent dust or water from entering the housing.
- DO NOT try to operate two or more actuators at the same time with only one operation switch. Other electrical equipment should not also be operated at the same time with one operation switch.
- Ensure the space heater to be activated all the time to keep the inside of the actuator warm for the prevention of due condensation, which may result in operational malfunction.
- Ensure the actuator is powered off, when it is used for manual operation.
- Place at least one-second interval, when the direction of operation is reversed. Failure to follow this instruction may result in operation malfunction.
- DO NOT make any unauthorized modifications. Such modifications may result in causing a troubled operation or accidents. We shall not be responsible for any troubles or accidents caused by improper use of the products.
- Refer to our catalogs for more details on valve information.

⚠ WARNING

- This product is not designed for explosion-proof. DO NOT use it in any inflammable or corrosive gaseous environment. Also DO NOT use it for handling inflammable fluid.
- DO NOT disassemble the actuator while the unit is being energized.
- DO NOT put your fingers or insert any foreign objects within the valve core before or during valve operation.

⚠ CAUTION

Technical data published in this catalog have been developed from our design calculation, in-house testing, field reports provided by our customers and/or published official standards or specifications. They are good only to cover typical applications as a general guideline to users of KITZ products introduced in this catalog.

For any specific application, users are kindly requested to contact KITZ Corporation for technical advice, or to carry out their own study and evaluation for providing suitability of these products to such an application. Failure to follow this request could result in property damage and/or personal injury, for which we shall not be liable.

While this catalog has been compiled with the utmost care, we assume no responsibility for errors, impropriety or inadequacy. Any information provided in this catalog is subject to from-time-to-time change without notice for error rectification, product discontinuation, design modification, new product introduction of any other cause that KITZ Corporation considers necessary. This edition cancels all previous issues.

KITZ

KELMO[®] EX SERIES

Electric Actuators for Ball and Butterfly Valves



ISO 9001 certified since 1989

KITZ

KITZ CORPORATION

1-10-1, Nakase, Mihama-ku, Chiba 261-8577, Japan
International Sales Dept. Phone: 81-43-299-1730, 1732 and 1733
Fax: 81-43-299-0121

— Distributed by —

0805①PP

KITZ CORPORATION

Next Generation Electrical Actuator

Realization of Upgraded General-Purpose Actuators EXSERIES

The modularization and the adoption of common parts have brought significant advantage to EXS and EXH series, such as :

Better Cost Performance

Compared with other equivalent actuators, EXS and EXH are superior in specification and performance.

Instant Option Availability

EXS and EXH can be used for various applications just by instant replacement of the modules of parts and exchangeable extension circuit boards.

Improvement of Operability and Maintenance

Easiness

In addition to modulation and adoption of common parts, the highly visible position indicator and manual handle also contribute to speedy maintenance.

Manual Override

An actuator can be manually operated by the easy-to-use round handle. Auxiliary hexagonal wrenches will make operation easier.

Position Indicator

The actuators come with the highly visible position indicator with a transparent cover as standard.

Precision Adjustable Cam / Standard Auxiliary Limit Switch

Cams are adjustable to precise position. Two auxiliary limit switches, in addition to two standard limit switches, are provided, which can be used for output signal with the voltage that users select. Two more auxiliary limit switches or a potentiometer can be added as an option. Special limit switches are available for extremely small ampere. (50mA or smaller)

Interlock Switch

The Interlock switch will cut off power supply by being pulled it up, which will ensure safe manual operation. The manual mode can be indicated by output signal.

Stainless Steel Exterior Bolting

All bolts used outside the actuator are made of stainless steel. Combined with the adoption of the fall-off-proof bolts, the actuator features high durability and reliability suitable for long service.

Adoption of Planetary Gear

A planetary gear is used in the output reduction gear system, which enables to achieve high reduction ratio with compact design.

EXH : High speed actuator for ball valves.

EXS : Standard speed actuator for ball valves and butterfly valves

Flexible Modification

The adoption of common parts and part modularization have enabled flexible modification, which will widen the applications of the actuator.

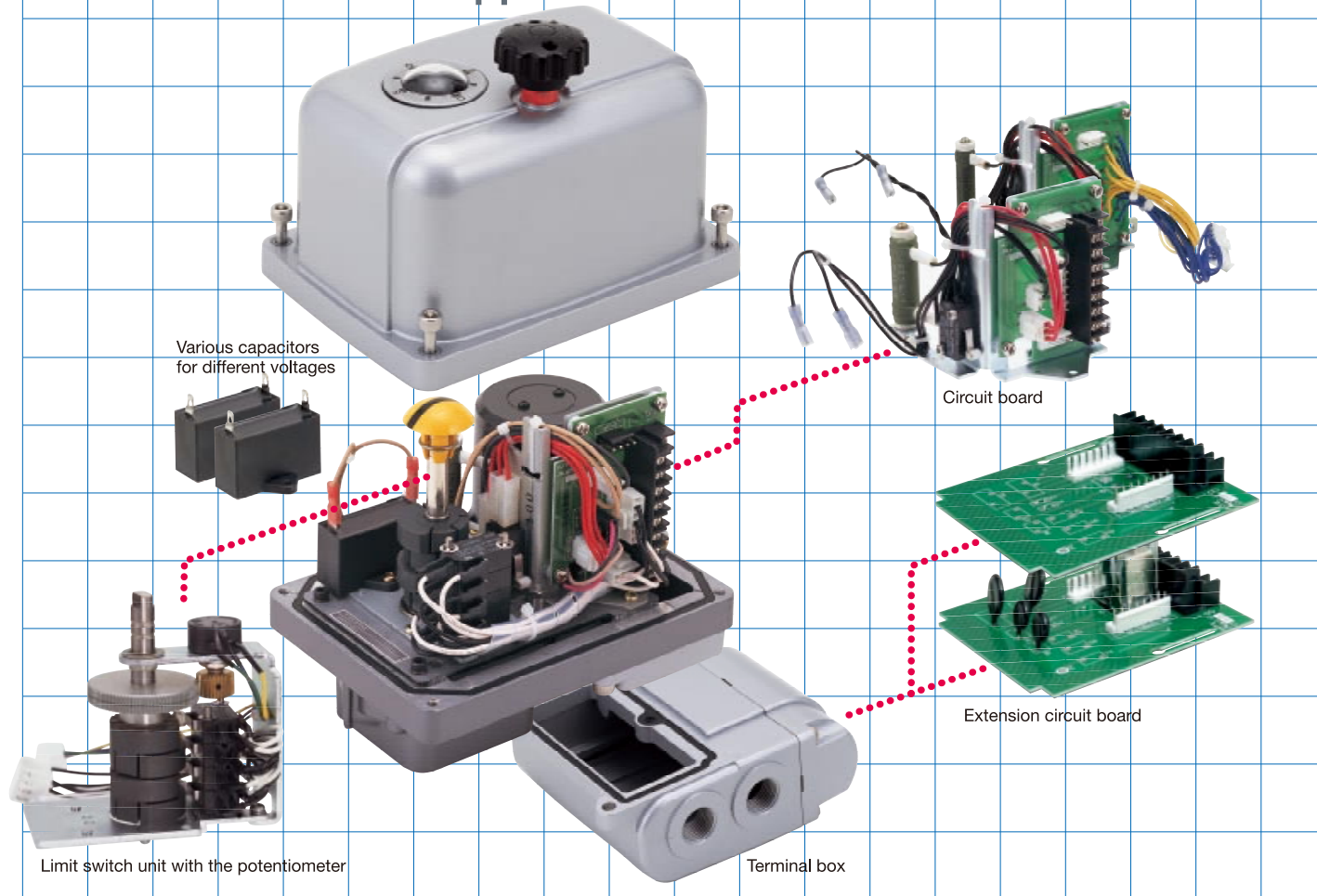

Optional specification

Power supply EXH EXS

- AC110V 50/60Hz
- AC115V 50/60Hz
- AC120V 60Hz
- AC220V 50/60Hz
- AC230V 50/60Hz
- AC240V 50Hz

AC115V 50Hz, AC120V 60Hz, AC230V 60Hz, AC240V
Allowable fluctuation of supply voltage is limited within between minus 10% and plus 5% for 50Hz.

Relays EXH EXS

Relays (on/off by a-contact) can be provided in the actuator by using extension circuit boards

Limit switch specification EXH EXS

Contact for Micro load (Minute electrical current)
Two standard limit switches can be replaced by optional limit switches for micro load (minute electrical current)

Potentiometer output EXH EXS

- 135Ω (Coil type)
 - 500Ω (Coil type)
- The valve opening degree is indicated by resistance value.

Auxiliary limit switch specification EXH EXS

Two more additional limit switches can be added.
Switches for micro load application are also available.
Including four standard limit switches, total six switches can be used. (In case the potentiometer is used, four limit switches in total can be used at maximum.)

Terminal box EXH

- G¹/₂ two conduit ports
- G³/₄ one conduit port
- NPT¹/₂ two conduit ports
- NPT³/₄ one conduit port
- M20 one conduit port

Terminal box with two G¹/₂ conduit port is equipped as standard for EXS type.
For EXH type, the use of the terminal box will enable the actuator to connect cables without removing the cover and to extend the actuator functions by using optional circuit boards.

Conduit port EXH EXS

- G³/₄, NPT¹/₂, NPT³/₄, M20

Specification

High-speed type For ball valve	EXH100/200-1	EXH100/200-2	EXH100/200-3	EXH100/200-4
Standard-speed type For butterfly valve and ball valve		EXS100/200-2	EXS100/200-3	EXS100/200-4
Power Supply	100/200V AC ±10% 50/60 Hz			
Output Torque (Nm)	9.8	49	196	588
Rated Current (A) *1	100V AC	0.65	1.2	2.8
	200V AC	0.35	0.35	1.5
Motor Type	Reversible			
Motor Output (W) (Rating)	16	16	31	85
Rotating Direction *2	Tuning clockwise to close and counterclockwise to open valves			
Duty Factor [%ED]	30	30	30	30
Valve Closing Time [SEC] *3	EXH 50Hz	9	21	28
	EXH 60Hz	8	17	23
	EXS 50Hz	—	35	49
	EXS 60Hz	—	30	41
Space Heater Volume [W]	100V AC	10	10	20
	200V AC	15	15	20
Position Limit Switch *4	Two switches with voltage and two without voltage supplied			
Switch Contact Voltage	250V AC 11A least resistance load			
Insulation Class	JIS Class E, Strength : 1500V AC 1min. or 1800V 1sec., Resistance : 100Ω minimum at 500V DC			
Overload Protection	Thermal protection			
Service Environment	Indoor / Outdoor (Submergence and direct sunlight must be avoided.)			
Water, Dust – Proof	Equivalent to IP-67			
Ambient Temperature	-10°C ~ +50°C			
Conduit Port	EXH	One G 1/2		
	EXS	Two G 1/2		
Mounting Position	From Vertical position to Horizontal position (No downward position)			
Manual Operation	Pull up the manual override handle knob for manual operation, which will activate the built-in interlock switch to cut off power supply. For the restoration of electrical operation, push down the handle knob			
Mechanical Stopper	EXH	Mechanical stoppers are equipped in open and closed position. The stoppers are adjustable by 7 degrees in the both positions		
	EXS	Mechanical stoppers, which can be adjusted in the closed position, are equipped in open and closed position		
Position Indicator	Position indicator, covered by transparent cover, is equipped on the top of the actuator cover			
Mounting Flange	In accordance with ISO5211			

*1 As the actuator is subjected to approx. tenfold rated current at startup, the contacts of electrical devices connected to the actuator must have enough capacity to handle this large electrical current.
*2 Refer to "Operation manual" for 3 way valves.
*3 Valve closing time is calculated based on an unloaded condition without the valve being mounted. The closing time will be 10% slower, when the valve is mounted.
*4 In case load current is 50 mA or smaller, use limit switches for micro load (minute current).

Circuit Diagram

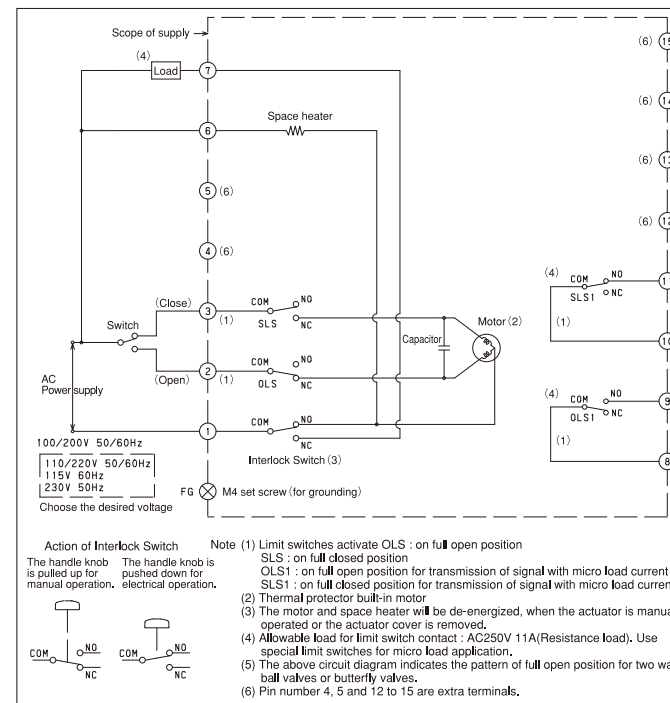

Product Code

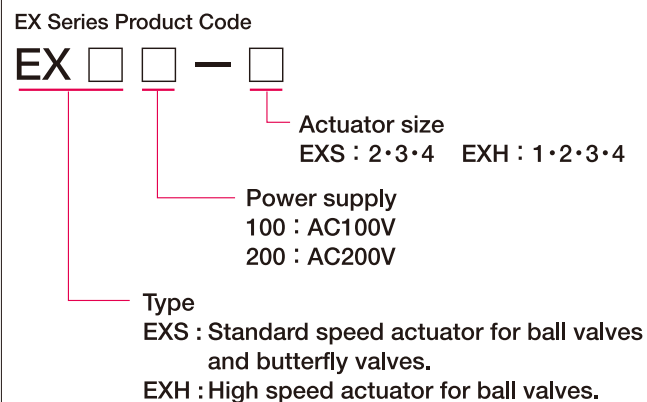

Dimensions

Type EXH

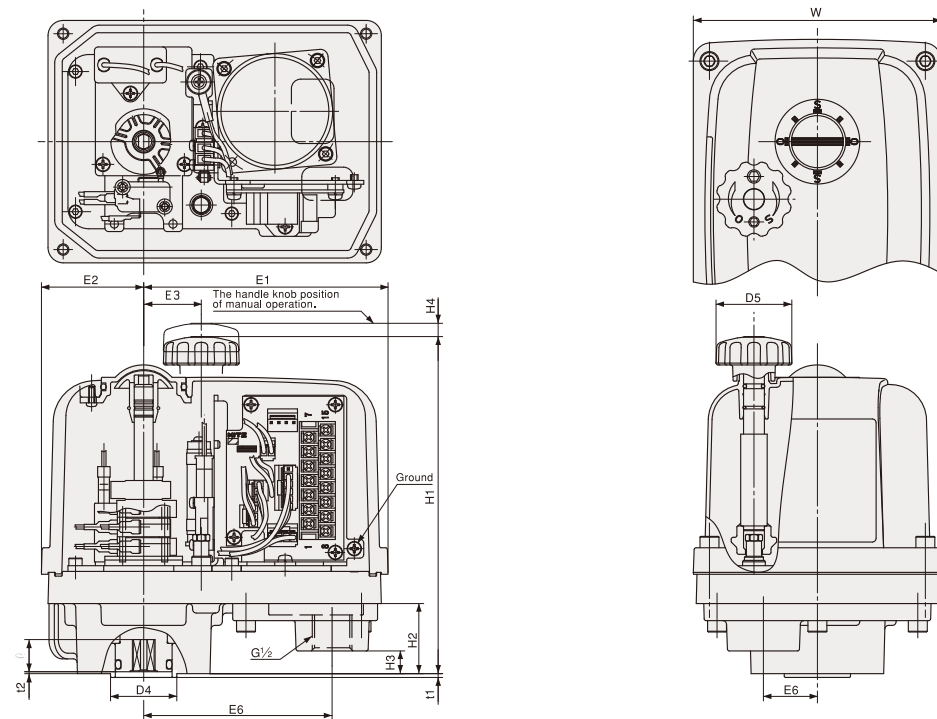

Type	E1	E2	E3	E4	E5	E6	W	H1	H2	H3	H4	H5	D1	D2	D3	D4	D5	∅	t1	t2
EXH100/200-1	129	54	30.4	33.5	99.5	28.5	131	181	37	12	10	107.5	50	70	—	35	40	16	2	1
EXH100/200-2	129	54	30.4	33.5	99.5	28.5	131	181	37	12	10	107.5	50	70	—	35	40	16	2	1
EXH100/200-3	152	69	45.1	42	123	28.5	158	206.5	44	19	10	117.5	50	70	102	55	60	25	2	1
EXH100/200-4	168	73	51.3	50	138.5	28.5	188	276	78	53	10	153	70	102	125	55	60	34	2	1

unit:mm

Type EXS

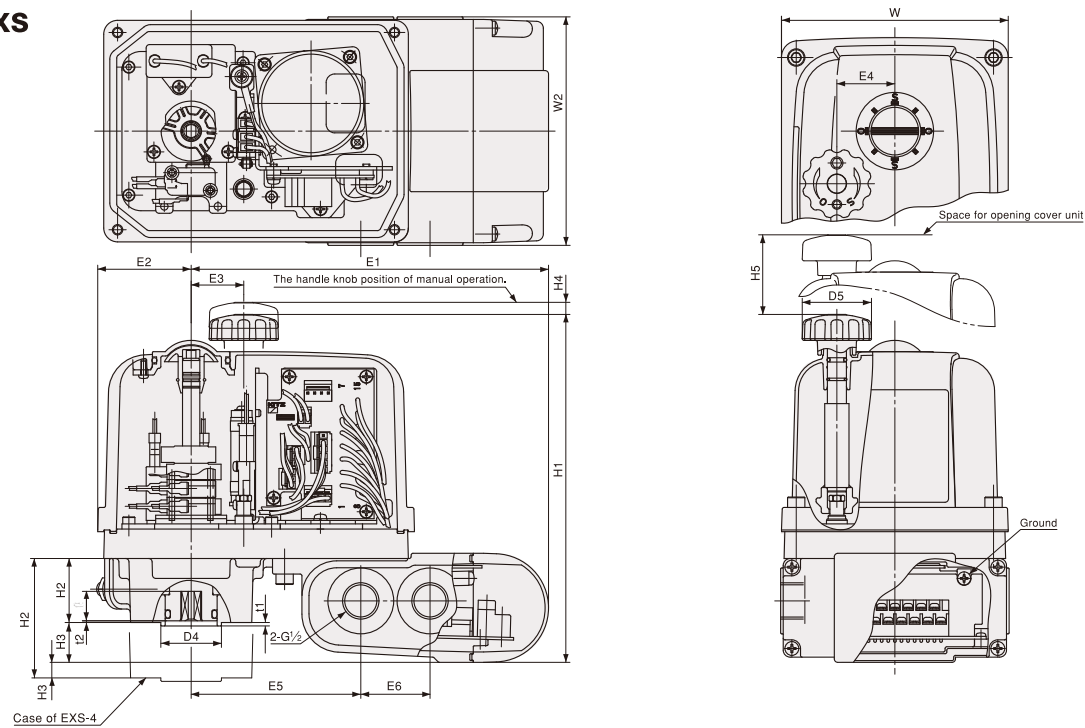

Type	E1	E2	E3	E4	E5	E6	W1	W2	H1	H2	H3	H4	H5	D1	D2	D3	D4	D5	∅	t1	t2
EXS100/200-2	206.5	54	30.4	33.5	98	40	131	132	204	37	23	10	107.5	50	70	—	35	40	16	2	1
EXS100/200-3	230	69	45.1	42	121.5	40	158	132	222.5	44	16	10	117.5	50	70	102	55	60	25	2	1
EXS100/200-4	245.5	73	51.3	50	137	40	188	132	258	78	18	10	153	70	102	125	55	60	34	2	1

unit:mm

Actuator Sizing

● Sizing condition : Ball valve

Service condition	Fluid	Clean fluid	Highly viscous fluid *2	Foreign particles included *3
Fluid type	Water, Lubricant	Standard sizing	○	○
	Air, gas or steam, 0.69 MPa or lower	Standard sizing	○	○
	Solvents *1	○	○	○
	Vacuum or Oil free service	○	○	○
Service temperature	Service temperature shall be limited by the seat material of the valve			

* Contact KITZ for actuator sizing, where mark ○ is indicated.
 *1 Solvents, such as Kerosene, naphtha or alcohol.
 *2 Viscosity ranges from 10000 CP to 50000 CP.
 *3 Inclusion of powder and slurry.

● Sizing condition : Butterfly valve

Fluid type	Smooth fluid (Clean water, lubricant, etc)
Velocity (Liquid)	3m/sec or slower

* Contact KITZ for advice when :
 • Service conditions do not meet those specified above.
 • Valve operation is interrupted for more than 3 months.

Type / Bore	Shell materials	Class	Connection	Product code	Size	mm												inch											
						10	15	20	25	32	40	50	65	80	100	125	150	200	250	300	3/8	1/2	3/4	1	1 1/4	1 1/2	2	2 1/2	3
Ball Valve / Full Bore	Cast Iron	JIS 10K	Threaded	10FCT	EXH-1	EXH-2 (EXS-2)	EXH-3 (EXS-3)	EXH-4 (EXS-4)	★	★	★	★	★	★	★	★	★	★	★	★	★	★							
				10FCTB																									
	10STBF																												
	Ductile Iron	JIS 10K Class 150	Flanged	10UTB·150UTB																									
				20UTB·300UTB																									
	Stainless Steel	JIS 10K Class 150	JIS 20K Class 300	Flanged																			10SCTB·150SCTB						
20SCTB·300SCTB																													
Carbon Steel	JIS 10K Class 150	JIS 20K Class 300	Flanged	150UTR																									
				300UTR																									
Ball Valve / Reduced Port	Stainless Steel	JIS 10K Class 150	JIS 20K Class 300	Flanged	150SCTR																								
					300SCTR																								
Ball Valve / Full Bore 3way	Stainless Steel	JIS 10K	Flanged	10UTB4T (L)A Note1	EXH-2	EXH-3	EXH-4	★	★	★	★	★	★	★	★	★	★	★	★	★	★	★							
				10UTBLN	EXH-1	EXH-2	EXH-3	★	★	★	★	★	★	★	★	★	★	★	★	★	★	★	★	★					
Butterfly Valve	Aluminum	JIS 10K	Wafer	10XJME Note2	EXS-2	EXS-3	EXS-4	★	★	★	★	★	★	★	★	★	★	★	★	★	★	★							
				10XJSME Note2																									
	10DJ																												
	16DJ, PN16DJ																												
	10UB																												
Ductile Iron	JIS 16K BS PN16	16UB																											
Stainless Steel	JIS 10K	JIS 16K	Wafer	10UB																									
				16UB																									

* Max. differential pressure : 0.49 MPa
 (Note 1) Consult KITZ, when the actuator is mounted on 3-way ball valves. The pattern of flow directional form is limited.
 (Note 2) Consult KITZ, when the actuator is mounted on manual operation valves. Special parts are needed to mount the actuator.

Dimensions of flange

Actuator	ISO Flange	Diameter of raised face	Axis side length	Axis depth
EXH-1	—	F05+F07	□9	16
EXH-2	EXS-2	F05+F07	□11	16
EXH-3	EXS-3	F05+F07+F10	□17	25
EXH-4	EXS-4	F07+F10+F12	□27	34