

KITZ Λ -port[®] Quarter-Turn Control Valves

JIS 10K·20K / ASME Class 150·300

Corrosion Resistant Bodies and Trims



KITZ Λ -port[®] disc

Specially designed for control and shut-off of slurries, highly viscous fluids and fibrous fluids, such as pulp and paper material in processes. Recommended as a more reliable substitution for conventional knife gate valves, featuring a quarter-turn drive mechanism to ease automated valve operation and a rigid structure for longer service life. Also reduces space requirements and eliminates concerns about stem leakage.

Λ : Call it "Lambda", which symbolizes the shape of the valve port, where its sharp edge cuts through all objects suspended in the line fluid while the valve is being closed.

Design Features

1. Sharp solid cutting

A trunnion mounted disc is sharply edged for cutting solids and fibrous objects mixed in line fluids, preventing disturbance to valve closing operation, and minimizing fluid residue within the valve bore.

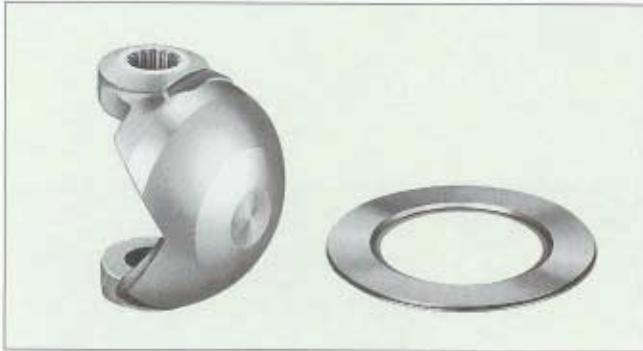

2. Choice of trims

Choice of two different trim configurations is available, depending on the planned service condition:

FLEKSEAT, made of spring steel Type 316, provides elasticity in its contact with the hard-chromium plated CF8M disc for higher sealing performance. Recommended for pulp and paper mill process control and services where higher sealing performance is critically required on valve shut-off. Always good for throttling service. (KITZ Fig. UVC)

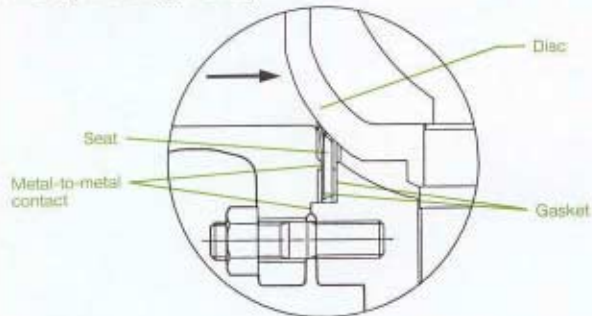

KNIFESEAT made of Stellite deposited steel Type 316, contacts hard-chromium plated CF8M disc for heavy duty services. Recommended for slurry service, and all other abrasion services. Also good for high viscosity services including pulp and paper mill processes. Always recommended for throttling service. (KITZ Fig. UVCT)

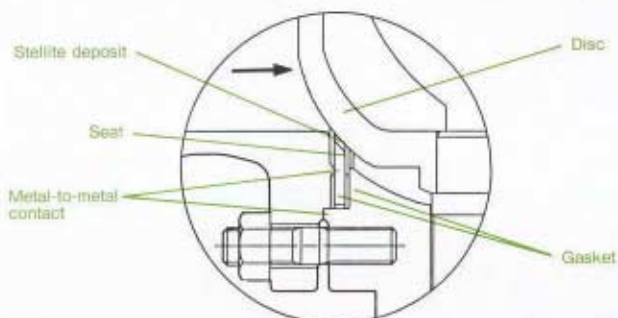

3. Structural reliability

Metal-to-metal contact is accommodated between body and cap, and between seat and cap, for correct seat centering and adequate depressing force. Spline shafted stem ends are firmly jointed with the disc for correct disc centering and higher operational durability. In addition, trunnion mounting of the disc on the body helps increase total structural reliability of the valve against extraordinary piping stress.

4. Stabilized operating torque

Metal backed PTFE stem bearings are employed on top and bottom stems for minimized and stabilized torque of valve operation. Fine finish of the disc surface and other sliding surfaces of components also helps smooth operation of the valve.

5. Maintenance ease

Two-piece split-body construction provides the convenience of easy maintenance which is always critically required for handling viscous or fibrous line fluids.

6. High flow efficiency

Full port design guarantees maximized and linearized flow characteristics with minimized pressure loss, helping viscous or fibrous line fluids pass through the valve bore smoothly.

7. Valve automation

Quarter-turn valve drive mechanism enables technically easier mounting of valve automation measures such as electric and pneumatic actuators. Integral pads are provided for easy, safe and assured on-the-spot actuator mounting without disassembly of valve glands, as required by ISO standard.

Note: Customers are requested to prepare mounting brackets and connectors chosen for their valve actuation as illustrated here.

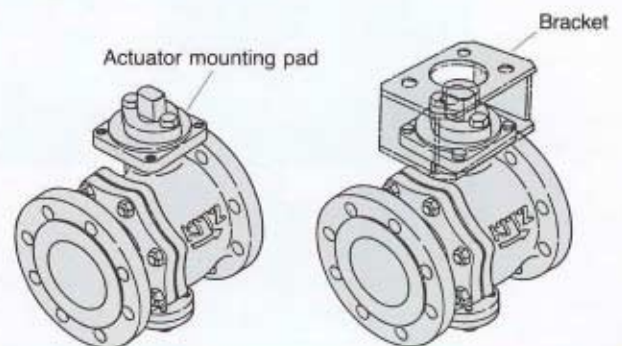

Caution: KITZ Λ -port® control valves are designed for uni-directional flow control. Be sure to mount the valve correctly so that the direction of line flow matches the direction of the arrow mark cast on the valve body.

KITZ Λ -port[®] Control Valves

Design Features

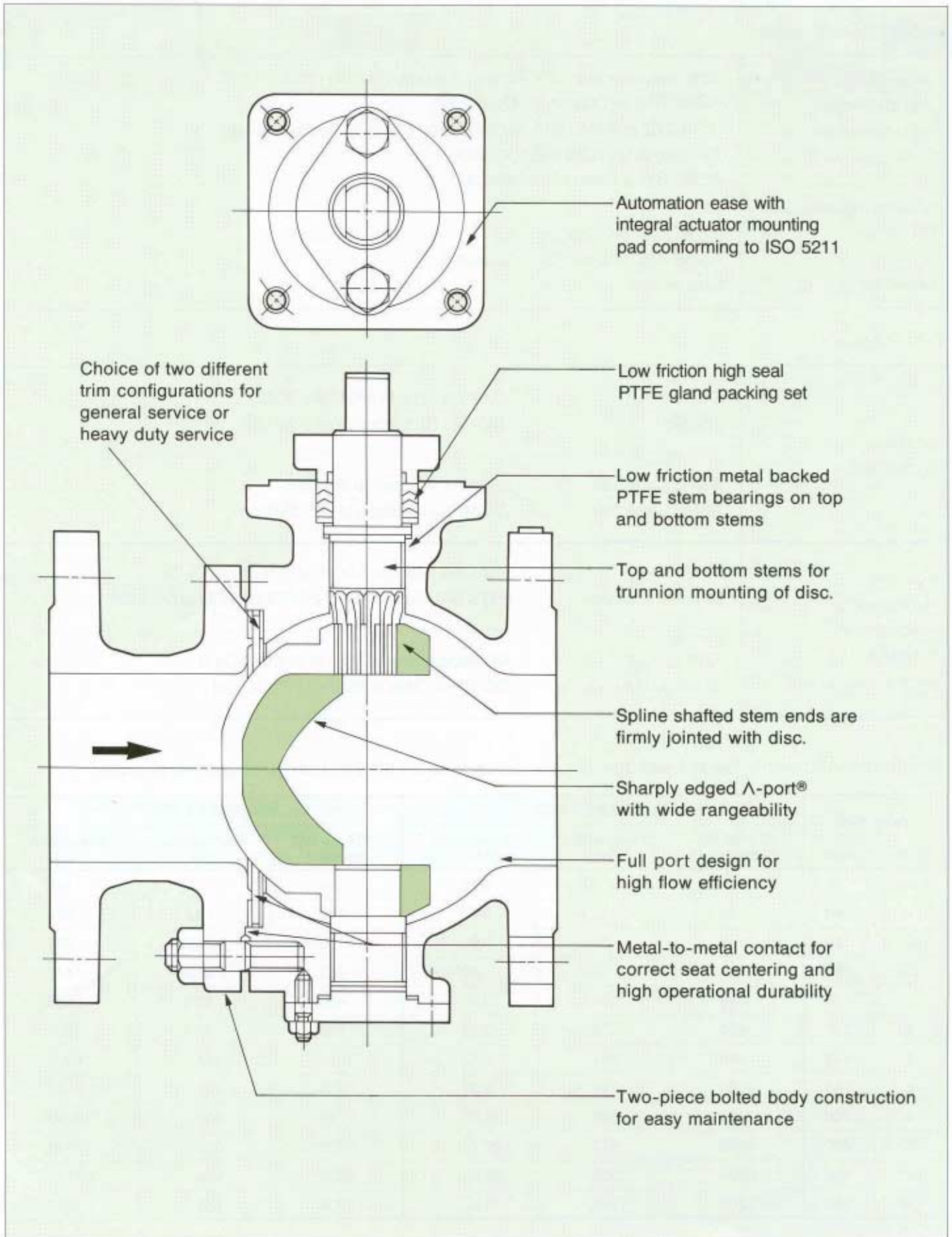

KITZ Λ -port® Control Valves

Design Data

Design specifications

Valve structure	Split body side entry, RF-flanged, full port, trunnion mounted disc
Wall thickness	ASME B16.34 Class 150 / Class 300
F-F dimensions	JIS B2002 or ASME B16.10 Class 150 / Class 300 for ball valves
End connection	RF-flanged to JIS B2238 10K / 20K or ASME B16.5 Class 150 / Class 300
Actuator mounting pad	ISO 5211
P-T rating	JIS B2238 10K / 20K or ASME B16.34 Class 150 / Class 300
Operation	Quarter-turn

Test Pressure

Shell test Hydrostatic	JIS 10K JIS 20K	2.06MPa (21kgf/cm ²) to JIS B2003 5.00MPa (51kgf/cm ²) to JIS B2003
	ASME Class 150 ASME Class 300	2.93MPa (450psi) to API 598 7.59MPa (1,125psi) to API 598
Seat test Hydrostatic or pneumatic at 0.39MPa (4kgf/cm ² or 60 psi)	FLEKSEAT for general service	Allowable leakage 0.0005% of Nominal Cv to IEC 534-4 Class IV-SI ANSI FCI 70-2 Class IV×0.05
	KNIFESEAT for heavy duty service	Allowable leakage 0.5% of Nominal Cv to IEC 534-4 Class II ANSI FCI 70-2 Class II

Maximum Allowable Seat Leakage [Per minute under 0.39MPa (4kgf/cm² or 60 psi) test pressure]

Valve size		FLEKSEAT (UVC)			KNIFESEAT (UVCT)		
		Cv at full opening	Hydrostatic (cc)	Pneumatic (Nl)	Cv at full opening	Hydrostatic (l)	Pneumatic (Nl)
1	25	25	3.6	0.16	31	4.42	193
1½	40	85	12.1	0.53	100	14.2	622
2	50	145	20.7	0.90	160	22.8	994
2½	65	240	34.2	1.49	265	37.8	1646
3	80	380	54.1	2.36	400	57.0	2486
4	100	550	78.3	3.42	585	83.4	3636
5	125	960	137	5.97	1010	144	6276
6	150	1500	214	9.32	1550	220	9632
8	200	2700	385	16.8	2750	392	17090
10	250	4300	613	26.7	4400	626	27340
12	300	6200	883	38.5	6300	898	39140
14	350	8200	1168	51.0	8300	1182	51580

Pressure-Temperature Rating

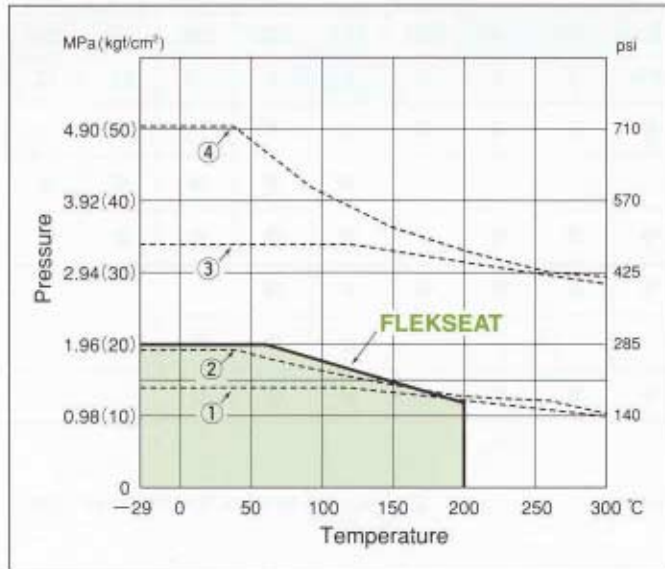

- ① Valve body rating to JIS B2238 10K steel
- ② Valve body rating to ASME B16.34 Class 150 CF8
- ③ Valve body rating to JIS B2238 20K steel
- ④ Valve body rating to ASME B16.34 Class 300 CF8

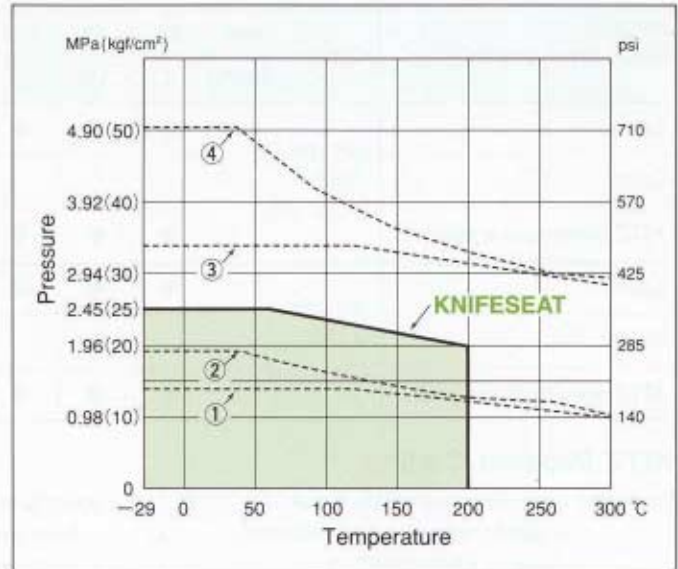

- ① Valve body rating to JIS B2238 10K steel
- ② Valve body rating to ASME B16.34 Class 150 CF8
- ③ Valve body rating to JIS B2238 20K steel
- ④ Valve body rating to ASME B16.34 Class 300 CF8

KNIFESEAT made of hard-faced heavy stainless steel is coupled with hard-faced stainless steel ball for handling slurries under high differential pressure, and handling fluid of high viscosity.

FLEKSEAT made of hard-faced flexible stainless steel and supported by stainless steel spring is recommended where higher sealing performance is required.

The products introduced in this catalog are all covered by the ISO 9001 Certification awarded KITZ Corporation in 1989, the earliest in the valve industry.

KITZ Λ -port® Control Valves

Product Range

Valve operation by	Class	mm	25	40	50	65	80	100	125	150	200	250	300	350
		inch	1	1½	2	2½	3	4	5	6	8	10	12	14
Lever	JIS 10K / ASME Class 150		●	●	●	●	●	●	●	●	●			
Gear										●	●	●	●	●
KITZ pneumatic actuators			●	●	●	●	●	●	●	●	●	●	●	●
Lever	JIS 20K / ASME Class 300		●	●	●	●	●	●	●	●	●			
Gear										●	●	●		
KITZ pneumatic actuators			●	●	●	●	●	●	●	●	●	●		

KITZ Product Coding

Example: Lever operated ASME Class 150 Λ -port® control valve, CF8M shell material, KNIFESEAT trim

L — **150** **U** **V** **C** **T** **M**

① ② ③ ④ ⑤ ⑥ ⑦

① Valve operational measure

L lever handle

G worm gear

B KITZ B-type double action pneumatic actuator

BS KITZ BS-type spring return pneumatic actuator

BSW KITZ BSW-type spring return pneumatic actuator

Refer to KITZ Cat.No. E-350 or C-350 for detailed information of KITZ pneumatic actuators

② Valve pressure class

150 ASME Class 150

10 JIS 10K

300 ASME Class 300

20 JIS 20K

③ Material symbol for stainless steel body

④ Symbol for Λ -port® control valve

⑤ Trunnion mounted disc

⑥ Trim symbol

T **KNIFESEAT** for heavy duty service

None ... **FLEKSEAT** for general service

⑦ Shell material

M **ASTM CF8M** or **JIS SCS14A**

None ... **ASTM CF8** or **JIS SCS13A**

This catalog uses **MPa**, a SI unit, for indication of pressures. For readers' convenience, however, **psi** and **kgf/cm²** are also used for **ANSI** and **JIS** related products respectively.

KITZ Λ -port® control valves were tested by Delft Hydraulics Laboratory in Delft, the Netherlands and various flow data such as valve flow coefficient, liquid pressure recovery factor, cavitation coefficient and torque coefficient were satisfactorily measured and certified by this internationally respected technical institute.



Test report



Delft Hydraulics Laboratory, Delft, the Netherlands

KITZ Λ -port® Control Valves

Dimensional Data

Class 150 / 10K Lever operated Λ -port® control valves

Trim	ASME Class 150	JIS 10K
FLEKSEAT	L-150UVC (M)	L-10UVC (M)
KNIFESEAT	L-150UVCT (M)	L-10UVCT (M)

In case of CF8M valve body, KITZ Fig. shall be suffixed with "M".

Valve size		d	L	L ₁	H	H ₁	D	mm
inch	mm							
1	25	25	127	48	181	68.5	160	
1½	40	38	165	67	198	76	230	
2	50	51	178	69	204	84.5	230	
2½	65	64	190	76	245	97	400	
3	80	76	203	77	252	106	400	
4	100	102	229	89	283	133.5	460	
5	125	127	356	158	305.5	157	460	
6	150	152	394	197	392	182	1000	
8	200	203	457	228.5	460	226.5	1500	

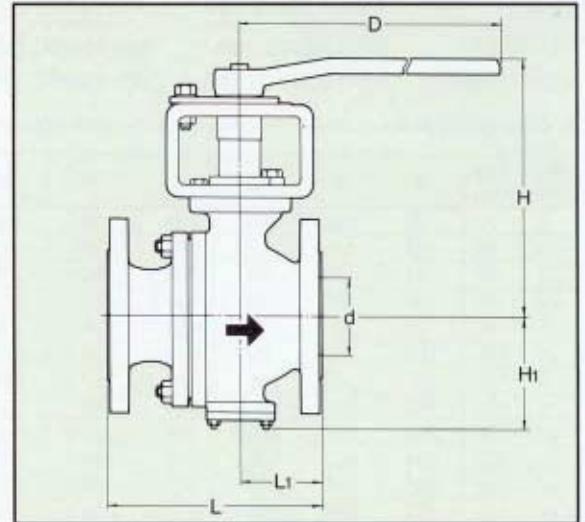

Class 150 / 10K Gear operated Λ -port® control valves

Trim	ASME Class 150	JIS 10K
FLEKSEAT	G-150UVC (M)	G-10UVC (M)
KNIFESEAT	G-150UVCT (M)	G-10UVCT (M)

In case of CF8M valve body, KITZ Fig. shall be suffixed with "M".

Valve size		d	L	L ₁	H	H ₁	D	A	mm
inch	mm								
6	150	152	394	197	330	182	310	65.5	
8	200	203	457	228.5	410	226.5	360	88.5	
10	250	254	533	266.5	446	268.5	500	93.5	
12	300	305	610	260	524	365.5	500	134	
14	350	337	686	293	547.5	403.5	500	134	

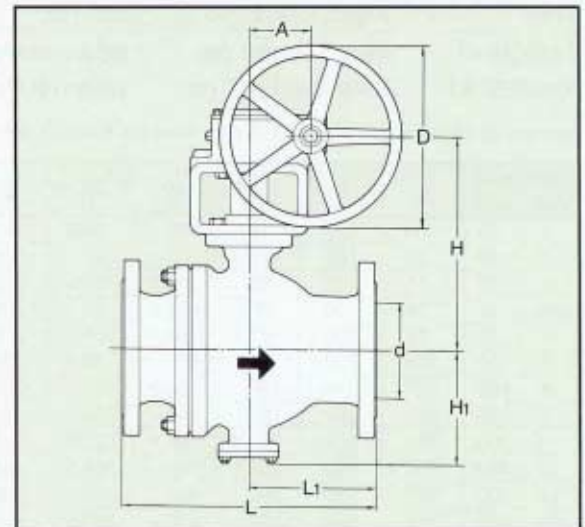

Class 150 / 10K KITZ B-type actuator operated Λ -port® control valves

Trim	ASME Class 150	JIS 10K
FLEKSEAT	B-150UVC (M)	B-10UVC (M)
KNIFESEAT	B-150UVCT (M)	B-10UVCT (M)

In case of CF8M valve body, KITZ Fig. shall be suffixed with "M".

Valve size		d	L	L ₁	H	H ₁	E	E ₁	Style	mm
inch	mm									
1	25	25	127	48	295	68.5	154	128	B-1	
1½	40	38	165	67	363	76	205	177	B-2	
2	50	51	178	69	369.5	84.5	205	177		
2½	65	64	190	76	447.5	97	272	235	B-3	
3	80	76	203	77	454	106	272	235		
4	100	102	229	89	479	133.5	272	235	B-4	
5	125	127	356	158	594.5	157	328	284		
6	150	152	394	197	614	182	328	284	B-5	
8	200	203	457	228.5	699	226.5	423	367		
10	250	254	533	266.5	746	268.5	423	367	B-6	
12	300	305	610	260	813	365.5	631	527		
14	350	337	686	293	850.5	403.5	631	527		

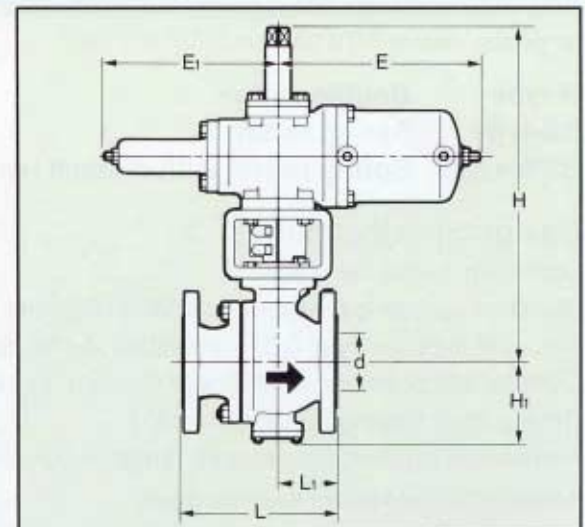

KITZ Λ -port® Control Valves

Dimensional Data

Class 150 / 10K KITZ BS-type actuator operated Λ -port® control valves

Trim	ASME Class 150	JIS 10K
FLEKSEAT	BS-150UVC (M)	BS-10UVC (M)
KNIFESEAT	BS-150UVCT (M)	BS-10UVCT (M)

In case of CF8M valve body, KITZ Fig. shall be suffixed with "M".

Valve size		d	L	L ₁	H	H ₁	E	E ₁	Style
inch	mm								
1	25	25	127	48	295	68.5	161	239	BS-1
1½	40	38	165	67	363	76	210	335	BS-2
2	50	51	178	69	369.5	84.5	210	335	
2½	65	64	190	76	447.5	97	276	451	BS-3
3	80	76	203	77	454	106	276	451	
4	100	102	229	89	479	133.5	276	451	BS-4
5	125	127	356	158	594.5	157	351	575	
6	150	152	394	197	614	182	351	575	BS-5
8	200	203	457	228.5	699	226.5	446	745	
10	250	254	533	266.5	746	268.5	446	745	BS-6
12	300	305	610	260	827	365.5	638	931	
14	350	337	686	293	850.5	403.5	638	931	

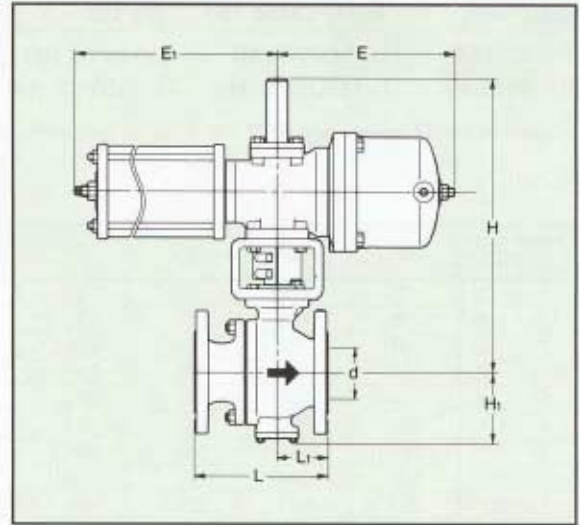

Class 150 / 10K KITZ BSW-type actuator operated Λ -port® control valves

Trim	ASME Class 150	JIS 10K
FLEKSEAT	BSW-150UVC (M)	BSW-10UVC (M)
KNIFESEAT	BSW-150UVCT (M)	BSW-10UVCT (M)

In case of CF8M valve body, KITZ Fig. shall be suffixed with "M".

Valve size		d	L	L ₁	H	H ₁	E	E ₁	Style
inch	mm								
1	25	25	127	48	295	68.5	161	259	BSW-1
1½	40	38	165	67	363	76	210	362	BSW-2
2	50	51	178	69	369.5	84.5	210	362	
2½	65	64	190	76	447.5	97	276	482	BSW-3
3	80	76	203	77	454	106	276	482	
4	100	102	229	89	479	133.5	276	482	BSW-4
5	125	127	356	158	594.2	157	351	609	
6	150	152	394	197	614	182	351	609	BSW-5
8	200	203	457	228.5	699	226.5	446	795	
10	250	254	533	266.5	746	268.5	446	795	BSW-6
12	300	305	610	260	827	365.5	638	1006	
14	350	337	686	293	850.5	403.5	638	1006	

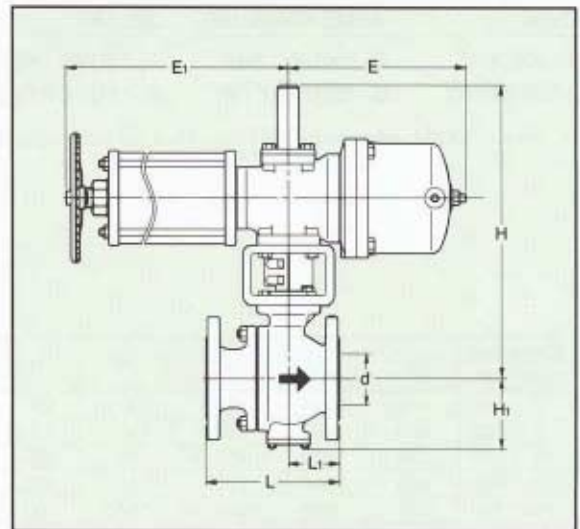

Profile of KITZ Pneumatic Actuators

for details, refer to KITZ Cat. No. E-350 or C-350.

- B-type :** Double action
- BS-type :** Spring return
- BSW-type :** Spring return with manual handwheel

Design Specifications

- Operating media: Air pressure
- Standard operating pressure: 0.39MPa (4kgf/cm² or 60psi)
- Pressure supply range: 0.39~0.69MPa (4~7kgf/cm² or 60~100psi)
- Cylinder test pressure: 0.97MPa (9.9kgf/cm² or 140psi)
- Driving shaft rotating angle: 90° (±5°)
- Permissible ambient temperature range: -20~+60°C (-4~+140°F)

Refer to Page 8 for Actuator Selection Guide.



KITZ Λ -port® Control Valves

Dimensional Data

Class 300 / 20K Lever operated Λ -port® control valves

Trim	ASME Class 300	JIS 20K
FLEKSEAT	L-300UVC(M)	L-20UVC(M)
KNIFESEAT	L-300UVCT(M)	L-20UVCT(M)

In case of CF8M valve body, KITZ Fig. shall be suffixed with "M".

Valve size		d	L	L ₁	H	H ₁	D
inch	mm						
1	25	25	165	68	181	71.5	160
1½	40	38	190	73.5	198	79	230
2	50	51	216	87.5	204	87.5	230
2½	65	64	241	102	245	100	400
3	80	76	283	120.5	252	109	400
4	100	102	305	125	283	133.5	460
5	125	127	381	158	305.5	157	460
6	150	152	403	182	392	182	1000
8	200	203	502	228.5	460	226.5	1500

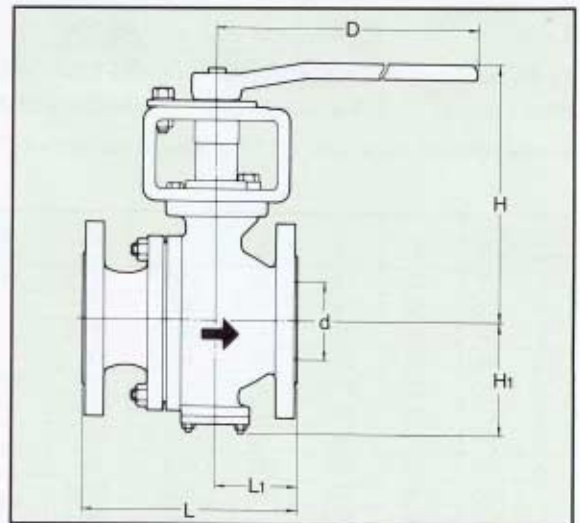

Class 300 / 20K Gear operated Λ -port® control valves

Trim	ASME Class 300	JIS 20K
FLEKSEAT	G-300UVC(M)	G-20UVC(M)
KNIFESEAT	G-300UVCT(M)	G-20UVCT(M)

In case of CF8M valve body, KITZ Fig. shall be suffixed with "M".

Valve size		d	L	L ₁	H	H ₁	D	A
inch	mm							
6	150	152	403	182	330	182	310	65.5
8	200	203	502	228.5	410	226.5	360	88.5
10	250	254	568	242.5	446	268.5	500	93.5

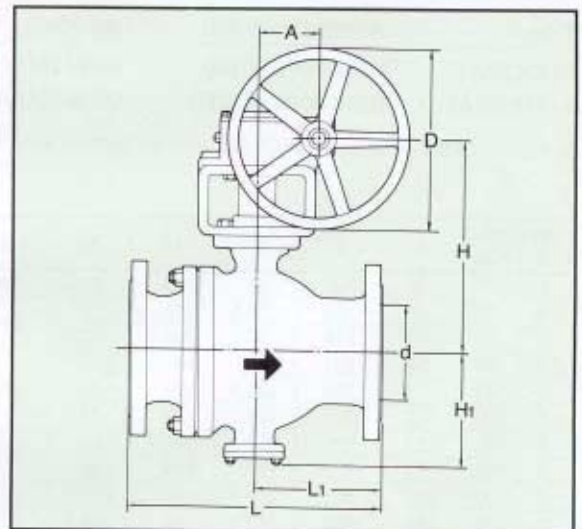

Class 300 / 20K KITZ B-type actuator operated Λ -port® control valves

Trim	ASME Class 300	JIS 20K
FLEKSEAT	B-300UVC(M)	B-20UVC(M)
KNIFESEAT	B-300UVCT(M)	B-20UVCT(M)

In case of CF8M valve body, KITZ Fig. shall be suffixed with "M".

Valve size		d	L	L ₁	H	H ₁	E	E ₁	Style
inch	mm								
1	25	25	165	68	295	71.5	154	128	B-1
1½	40	38	190	73.5	363	79	205	177	B-2
2	50	51	216	87.5	369.5	87.5			
2½	65	64	241	102	447.5	100	272	235	B-3
3	80	76	283	120.5	454	109			
4	100	102	305	125	479	133.5	328	284	B-4
5	125	127	381	158	594.5	157			
6	150	152	403	182	614	182	423	367	B-5
8	200	203	502	228.5	699	226.5			
10	250	254	568	242.5	746	268.5			

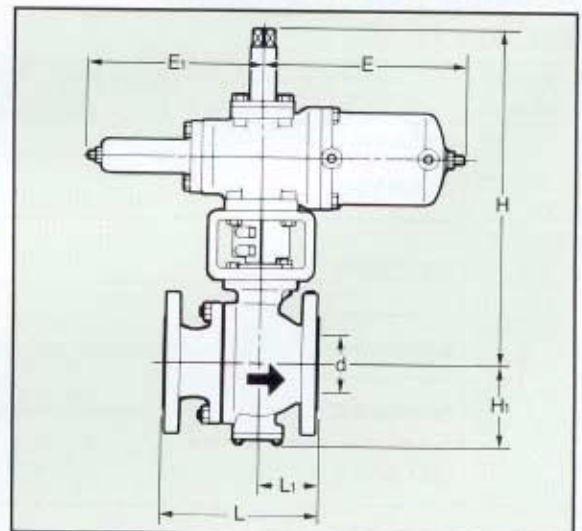

KITZ Λ -port® Control Valves

Dimensional Data

Class 300 / 20K KITZ BS-type actuator operated Λ -port® control valves

Trim	ASME Class 300	JIS 20K
FLEKSEAT	BS-300UVC(M)	BS-20UVC(M)
KNIFESEAT	BS-300UVCT(M)	BS-20UVCT(M)

In case of CF8M valve body, KITZ Fig. shall be suffixed with "M".

Valve size		d	L	L ₁	H	H ₁	E	E ₁	Style
inch	mm								
1	25	25	165	68	295	71.5	161	239	BS-1
1½	40	38	190	73.5	363	79	210	335	BS-2
2	50	51	216	87.5	369.5	87.5			
2½	65	64	241	102	447.5	100	276	451	BS-3
3	80	76	283	120.5	454	109			
4	100	102	305	125	479	133.5	351	575	BS-4
5	125	127	381	158	594.5	157			
6	150	152	403	182	614	182	446	745	BS-5
8	200	203	502	228.5	699	226.5			
10	250	254	568	242.5	746	268.5			

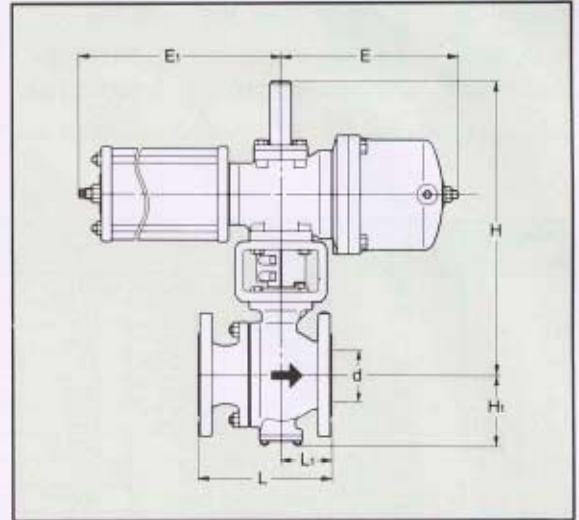

Class 300 / 20K KITZ BSW-type actuator operated Λ -port® control valves

Trim	ASME Class 300	JIS 20K
FLEKSEAT	BSW-300UVC(M)	BSW-20UVC(M)
KNIFESEAT	BSW-300UVCT(M)	BSW-20UVCT(M)

In case of CF8M valve body, KITZ Fig. shall be suffixed with "M".

Valve size		d	L	L ₁	H	H ₁	E	E ₁	Style
inch	mm								
1	25	25	165	68	295	71.5	161	259	BSW-1
1½	40	38	190	73.5	363	79	210	362	BSW-2
2	50	51	216	87.5	369.5	87.5			
2½	65	64	241	102	447.5	100	276	482	BSW-3
3	80	76	283	120.5	454	109			
4	100	102	305	125	479	133.5	351	609	BSW-4
5	125	127	381	158	594.5	157			
6	150	152	403	182	614	182	446	795	BSW-5
8	200	203	502	228.5	699	226.5			
10	250	254	568	242.5	746	268.5			

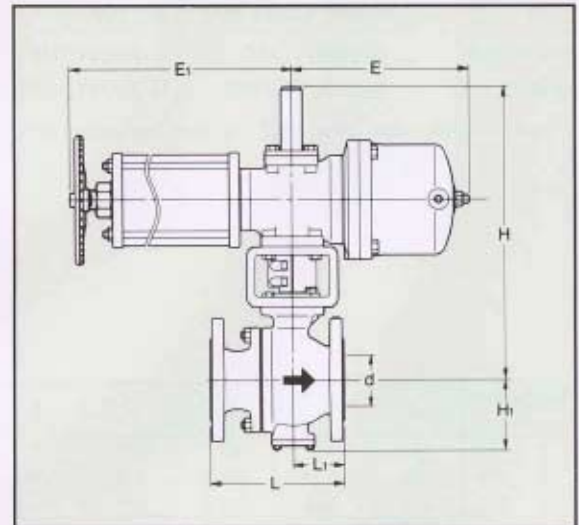

Actuator Selection Guide

FLEKSEAT

Valve size	Differential pressure (Δp) MPa (kgf/cm ² or psi)						
	inch	mm	0.49 (5 or 70)	0.98 (10 or 140)	1.47 (15 or 210)	1.96 (20 or 280)	2.45 (25 or 350)
1	25	B/BS/BSW-1					
1½	40	B/BS/BSW-2					
2	50						
2½	65	B/BS/BSW-3					
3	80						
4	100	B/BS/BSW-4					
5	125						
6	150	B/BS/BSW-5					
8	200						
10	250	B/BS/BSW-6					
12	300						
14	350						

KNIFESEAT

Valve size	Differential pressure (Δp) MPa (kgf/cm ² or psi)						
	inch	mm	0.49 (5 or 70)	0.98 (10 or 140)	1.47 (15 or 210)	1.96 (20 or 280)	2.45 (25 or 350)
1	25	B/BS/BSW-1					
1½	40	B/BS/BSW-2					
2	50						
2½	65	B/BS/BSW-3					
3	80						
4	100	B/BS/BSW-4					
5	125						
6	150	B/BS/BSW-5					
8	200						
10	250	B/BS/BSW-6					
12	300						
14	350						

KITZ Λ-port® Control Valves

Construction and Materials

Standard Parts and Materials (UVC/UVCT)

No.	Parts	JIS	ASTM
1	Body	SCS13A ※1	CF8 ※2
2	Body cap	SCS13A ※1	CF8 ※2
3	Stem	SUS316	Type 316
4	Disc	SCS14A Cr plated	CF8M Cr plated
7	Gland	SCS13A	CF8
8	Gland packing	PTFE	PTFE
19A	Seat gasket	Asbestos ※5	Asbestos ※5
19B	Gasket	Asbestos ※5	Asbestos ※5
20	Packing washer	SUS316	Type 316
30	Seat	SUS316 (UVC) SUS316 Hard faced (UVCT)	Type 316 (UVC) Type 316 Hard faced (UVCT)
31	Stem washer	SUS316	Type 316
33A	Cap nut	SUS304	8
33B	Cover nut	SUS304	8
35A	Cap bolt	SUS304	B8
35B	Cover bolt	SUS304	B8
36	Gland bolt	SUS304	B8
47A	Thrust washer	Glass filled PTFE	Glass filled PTFE
47B	Thrust washer	Glass filled PTFE	Glass filled PTFE
47C	Thrust washer	Glass filled PTFE	Glass filled PTFE
67	Stem bearing	Metal backed PTFE	Metal backed PTFE
103	Bottom stem	SUS316	Type 316
147	End plate	SUS304 ※3	Type 304 ※4
155	Shim	SUS316	Type 316

Special Materials for UVC/UVCTM

- ※ 1. SCS14A
- ※ 2. CF8M
- ※ 3. SUS316
- ※ 4. Type 316
- ※ 5. Non-asbestos gaskets are optionally available

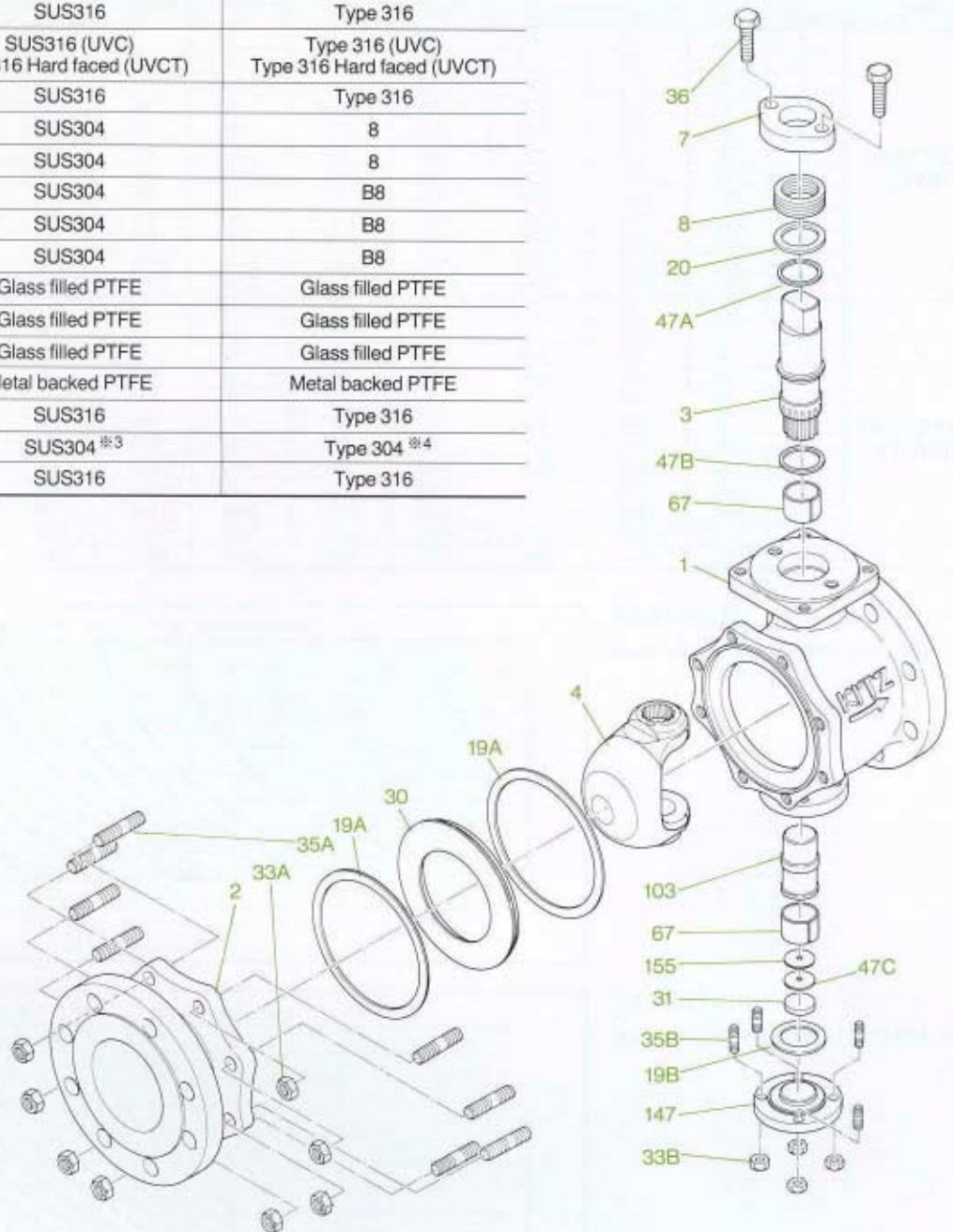

KITZ Λ -port® Control Valves

Flow Characteristics

One advantage of KITZ Λ -port® control valves is more efficient flow characteristics than other types of control valves, due to its full port design. For correct determination of valve size, find the accurate valve flow coefficient by means of the flow equation detailed on Page 12 and compare with Cv values introduced on page 10 and 11. Valve opening by 40% to 80% is usually recommended for smooth fluid control.

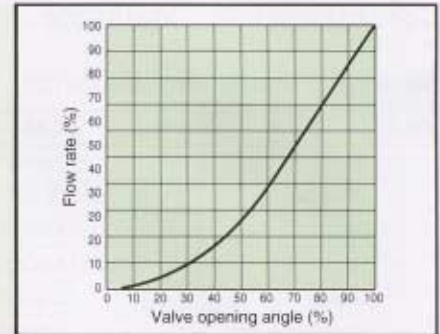

Flow Coefficient (Cv) by Valve Opening Angle for ASME Class 150 (10K) Λ -port® control valves

Seat	Valve size		Valve opening angle (%)										
	inch	mm	100	90	80	70	60	50	40	30	20	10	
FLEKSEAT (UVC)	1	25	25	23	19	15	11	7.8	4.6	2.2	0.5	—	
	1 1/2	40	85	74	60	45	32	22	13	7.4	3	—	
	2	50	145	125	100	78	55	37	23	13	6.2	—	
	2 1/2	65	240	205	165	130	90	60	37	20	10	—	
	3	80	380	330	270	200	145	95	57	30	15	5.2	
	4	100	550	480	400	310	220	145	92	51	24	8.8	
	5	125	960	810	650	490	350	240	146	82	38	13	
	6	150	1500	1260	1020	780	570	380	240	130	62	18	
	8	200	2700	2300	1800	1350	950	640	400	235	115	42	
	10	250	4300	3650	2900	2250	1600	1120	700	400	200	72	
	12	300	6200	5200	4300	3300	2450	1680	1060	620	310	106	
	14	350	8200	7100	5900	4600	3400	2300	1460	850	440	135	
	KNIFESEAT (UVCT)	1	25	31	28	24	19	14	9.5	5.5	2.6	0.6	—
		1 1/2	40	100	85	69	53	38	25	16	8.5	3.5	—
2		50	160	138	110	84	60	40	25	14	6.9	—	
2 1/2		65	265	230	185	140	99	66	41	22	10	—	
3		80	400	345	280	215	155	100	61	33	15	5.5	
4		100	585	510	420	320	230	155	96	55	26	9.5	
5		125	1010	870	700	530	380	250	156	88	41	14	
6		150	1550	1320	1080	840	610	410	250	140	65	19	
8		200	2750	2340	1830	1370	970	650	410	240	120	43	
10		250	4400	3700	2950	2300	1660	1140	720	410	205	4	
12		300	6300	5300	4400	3400	2500	1700	1080	630	320	110	
14		350	8300	7200	5900	4600	3400	2350	1480	860	440	140	

FLEKSEAT

(10 / 150 UVC for general service)

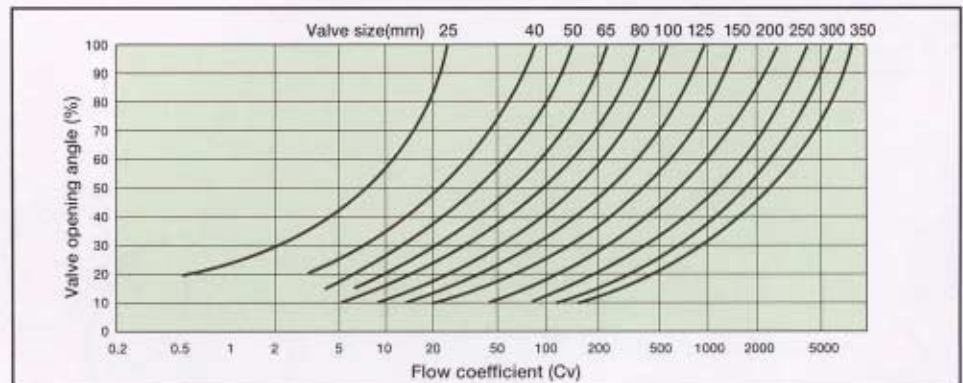

KNIFESEAT

(10 / 150 UVCT for heavy duty service)

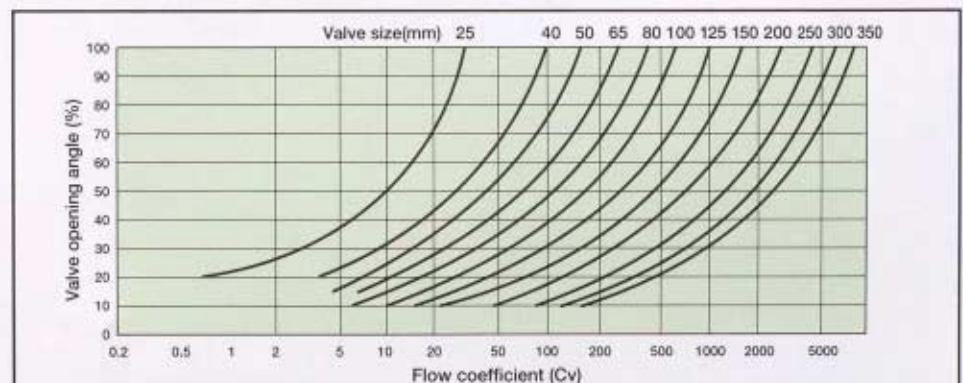

KITZ Λ -port® Control Valves

Flow Coefficient (Cv) by Valve Opening Angle for ASME Class 300 (20K) Λ -port® control valves

Seat	Valve size		Valve opening angle (%)									
	inch	mm	100	90	80	70	60	50	40	30	20	10
FLEKSEAT (UVC)	1	25	22	20	19	15	11	7.8	4.6	2.2	0.5	—
	1½	40	79	66	60	45	32	22	13	7.4	3	—
	2	50	132	125	100	78	55	37	23	13	6.2	—
	2½	65	217	193	165	130	90	60	37	20	10	—
	3	80	322	301	270	200	145	95	57	30	15	5.2
	4	100	476	441	400	310	220	145	92	51	24	8.8
	6	150	1480	1240	1020	780	570	380	240	130	62	18
	8	200	2570	2160	1800	1350	950	640	400	235	115	42
10	250	4160	3510	2900	2250	1600	1120	700	400	200	72	
KNIFESEAT (UVCT)	1	25	27	26	24	19	14	9.5	5.5	2.6	0.6	—
	1½	40	96	84	69	53	38	25	16	8.5	3.5	—
	2	50	145	128	110	84	60	40	25	14	6.9	—
	2½	65	235	211	185	140	99	66	41	22	10	—
	3	80	339	315	280	215	155	100	61	33	15	5.5
	4	100	507	465	420	320	230	155	96	55	26	9.5
	6	150	1530	1300	1080	840	610	410	250	140	65	19
	8	200	2620	2200	1830	1370	970	650	410	240	120	43
10	250	4260	3730	2950	2300	1660	1140	720	410	205	74	

FLEKSEAT
(20 / 300 UVC for general service)

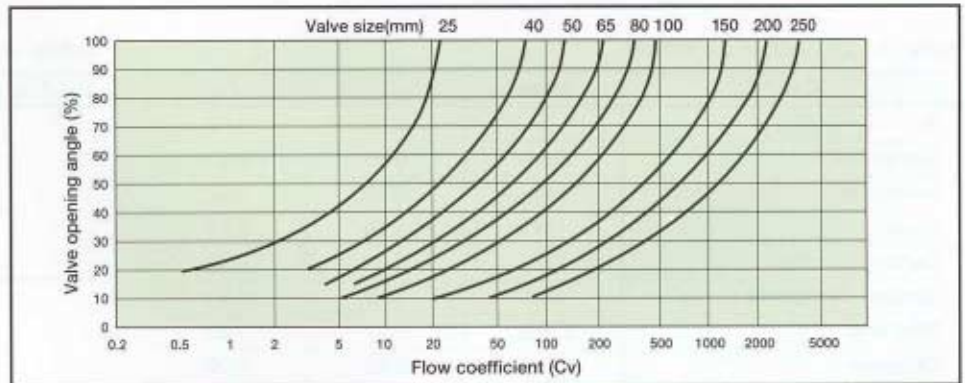

KNIFESEAT
(20 / 300 UVCT for heavy duty service)

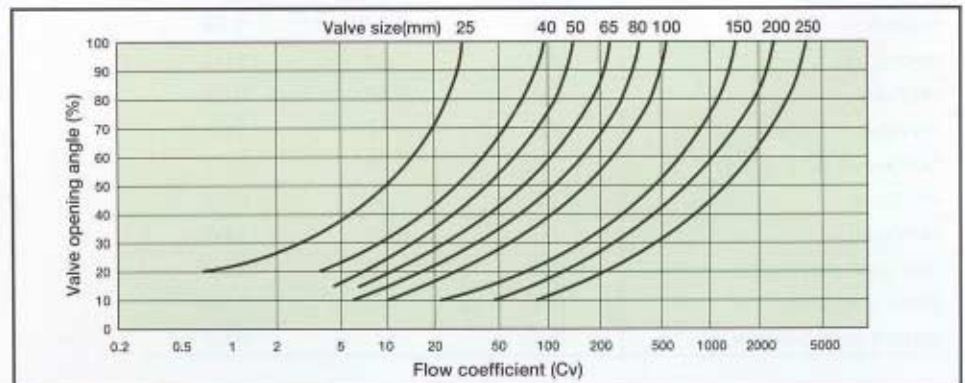

Flow Equation

Fluid	Service condition	Equation
Liquid	Sub-critical condition $\Delta P < F_L^2 (P_1 - P_V)$	$C_V = 1.17 \cdot Q_L \cdot \sqrt{\frac{G_L}{\Delta P}}$ or ^(**1) $C_V = \frac{1.17 \cdot W_L}{\sqrt{\Delta P \cdot G_L}}$
	Critical condition $\Delta P \geq F_L^2 (P_1 - P_V)$	$C_V = \frac{1.17 \cdot Q_L}{F_L} \cdot \sqrt{\frac{G_L}{(P_1 - P_V)}}$ or $C_V = \frac{1.17 \cdot W_L}{F_L \cdot \sqrt{(P_1 - P_V) \cdot G_L}}$
Gas	$X < F_K \cdot X_T$	$C_V = \frac{Q_g}{387 \cdot P_1 \cdot Y} \cdot \sqrt{\frac{G_g \cdot T_1 \cdot Z}{X}}$ or $C_V = \frac{W_g}{27.1 \cdot Y \cdot \sqrt{X \cdot P_1 \cdot \gamma_1}}$
	$X \geq F_K \cdot X_T$	$C_V = \frac{Q_g}{258 \cdot P_1} \cdot \sqrt{\frac{G_g \cdot T_1 \cdot Z}{F_K \cdot X_T}}$ or $C_V = \frac{W_g}{18.1 \cdot \sqrt{F_K \cdot X_T \cdot P_1 \cdot \gamma_1}}$
Saturated steam	$X < F_K \cdot X_T$	$C_V = \frac{W_g}{19.3 \cdot P_1 \cdot Y \cdot \sqrt{X}}$
	$X \geq F_K \cdot X_T$	$C_V = \frac{W_g}{12.9 \cdot P_1 \cdot \sqrt{F_K \cdot X_T}}$
Superheated steam	$X < F_K \cdot X_T$	$C_V = \frac{W_g \cdot (1 + 0.00126 \cdot \Delta t)}{19.3 \cdot P_1 \cdot Y \cdot \sqrt{X}}$
	$X \geq F_K \cdot X_T$	$C_V = \frac{W_g \cdot (1 + 0.00126 \cdot \Delta t)}{12.9 \cdot P_1 \cdot \sqrt{F_K \cdot X_T}}$

Nomenclature

(Symbol, description and unit)

- C_V : Valve flow coefficient
 F_L : Liquid pressure recovery factor of a valve without attached fittings, dimensionless
 0.58 for fully opened full-bore Λ -port valve
 G_L : Liquid specific gravity (1.0 for water)
 P_1 : Upstream absolute static pressure (kgf/cm²A)
 P_2 : Downstream absolute static pressure (kgf/cm²A)
 P_V : Absolute vapor pressure of liquid at inlet temperature (kgf/cm²A)
 ΔP : Differential pressure ($P_1 - P_2$) (kgf/cm²)
 Q_L : Volumetric flow rate of liquid (m³/h)
 W_L : Weight or mass flow rate of liquid (t/h)
 G_g : Gas specific gravity (1 for air. Refer to Table 1)
 Q_g : Gas volumetric specific gravity (Nm³/h)
 X : Ratio of pressure drop ($\Delta P/P_1$)
 X_T : Pressure drop ratio factor, dimensionless
 0.25 for fully opened full-bore Λ -port valve
 W_g : Gas or steam weight or mass flow rate (kg/h)
 γ_1 : Specific gravity, upstream conditions (kg/m³)
 F_K : Ratio of specific heats factor, dimensionless
 (1 for air. Refer to Table 1)
 = Ratio of specific heats / 1.4
 Y : Expansion factor = $1 - \frac{X}{3 \cdot F_K \cdot X_T}$
 T_1 : Absolute upstream temperature (°K)
 Δt : Upstream superheated steam temperature (°C)
 Z : Compressibility factor, dimensionless = 1 ^(**2)

**1: In case of servicing pulp, Q_g shall be applied instead of Q_L . Here, $Q_g = Q_L \cdot F_C$ (Correction factor of pulp density. Refer to Table 2)

**2: Detailed value may be determined by means of using, as a parameter, reduced pressure (Pr) and reduced temperature (Tr). Here, $Pr = P_1 / P_C$ (absolute thermodynamic critical pressure)
 $Tr = T_1 / T_C$ (absolute thermodynamic critical temperature)

Table 1 Gg and F_K Factors

Gas	Note	Gg	F _K
Air	—	1.00	1.00
Acetylene	C ₂ H ₂	0.90	0.91
Ammonia	NH ₃	0.59	0.92
Argon	Ar	1.38	1.19
Carbon dioxide	CO ₂	1.52	0.91
Carbon monoxide	CO	0.97	1.01
Ethylene	C ₂ H ₄	0.97	0.87
Chlorine	Cl ₂	2.49	0.96
Ethan	C ₂ H ₆	1.05	0.87
Helium	He	0.14	1.19
Hydrogen	H ₂	0.07	1.00
Methan	CH ₄	0.55	0.90
Oxygen	O ₂	1.10	1.00
Sulfurous acid (gas)	SO ₂	2.21	0.89
Propane	C ₃ H ₈	1.56	0.81
Nitrogen	N ₂	0.97	1.00
Nitrogen monoxide	NO	1.03	1.00
Saturated steam	H ₂ O	—	0.94
Superheated steam	H ₂ O	—	0.94

Table 2

Pulp density (%)	Correction factor (F _C)
1	1.00
2	1.05
3	1.15
4	1.22
5	1.30

Valve Disassembly and Reassembly for Maintenance

1. Valve Disassembly

- 1-1. Works to do before valve dismantling from the pipeline:
 - (a) Release the line pressure completely and discharge all line fluids from the bore and body cavity of the valve.
 - (b) Mark the valve end flanges and coupled piping flanges adequately for easy remounting of the valve on the pipeline.
- 1-2. Works to do before valve disassembly:
 - (a) Remove and collect all inside residues of the valve, if there is any, and record their conditions and locations. Subsequent examination of these records may be found useful for better valve maintenance.
 - (b) Mark the body-cap coupling flanges of the valve adequately for easy valve reassembly.
 - (c) If flange boltings are found seized or stuck each other, apply some lubricant and leave it for a while for easier unthreading on valve disassembly.
- 1-3. Place the valve with the body flange down on the work bench, and proceed with disassembly of the cap from the body, referring to the illustration of Page 9. (No special tool is required.) Be careful not to damage the valve seat, which is the most important valve part.
- 1-4. After removal of the cap, place the valve body with "KITZ" mark up on the bench, and proceed with disassembly of the disc. Put soft clothes inside the valve body not to damage the disc, which is also an important member of the valve components.
- 1-5. Examination of the valve component parts:
 - (a) Clean the inside of the valve body and cap, and detect any wear, corrosion or crack of the castings using a magnifying glass, or, where visual access is not easy, using a tube inspector or a mirror and a flashlight. Non-destructive examination may be carried out if found necessary. Measure the wall thickness of castings periodically to check any dangerous sign to jeopardize valve shell soundness.
 - (b) Inspect surfaces of the valve seat and disc carefully to detect any scratch or wear, which may be a cause to replace the seat and/or disc on reassembly. Other metal parts must be also checked carefully to decide whether they are still usable.

2. Valve Reassembly

- 2-1. Prepare new non-metal valve parts such as gaskets, packings, thrust washers, gland bushes and stem bearings, and clean all metal parts before reassembly.
- 2-2. Proceed with valve reassembly, referring to the illustration of Page 9.

3. Acceptance Test

After reassembly, open and close the valve several times to check satisfactory valve operation. Then pressure-test the valve according to the specifications given on Page 2 to ensure the satisfactory sealing performance for final acceptance.



CAUTION

Pressure-temperature ratings and other performance data published in this catalog have been developed from our design calculation, in-house testing, field reports provided by our customers and/or published official standards or specifications. They are good only to cover typical applications as a general guideline to users of KITZ products introduced in this catalog.

For any specific application, users are kindly requested to contact KITZ Corporation for technical advice, or to carry out their own study and evaluation for proving suitability of these products to such an application. Failure to follow this request could result in property damage and/or personal injury, for which we shall not be liable.

While this catalog has been compiled with the utmost care, we assume no responsibility for errors, impropriety or inadequacy. Any information provided in this catalog is subject to from-time-to-time change without notice for error rectification, product discontinuation, design modification, new product introduction or any other cause that KITZ Corporation considers necessary. This edition cancels all previous issues.

ISO 9001 certified since 1989

KITZ

KITZ CORPORATION OF AMERICA

10750 Corporate Drive, Stafford, Texas 77477, U.S.A.

Phone: 281-491-7333 Fax: 281-491-9402

— Distributed by —