

Diaphragm Valve – SRL Weir- Flanged Undrilled

标记	分区	更改内容	签名	年月日

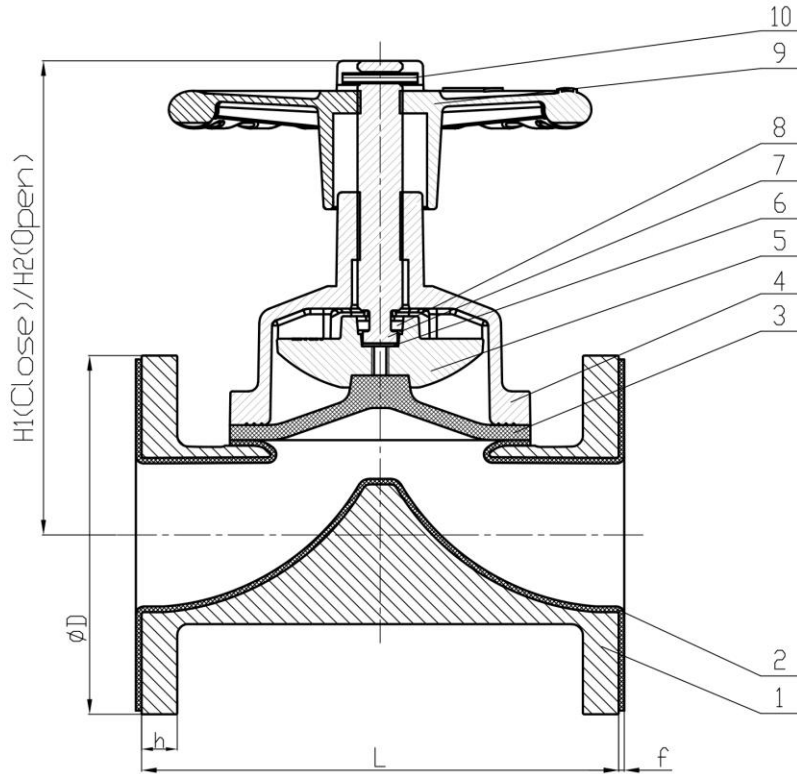

Technical Requirements:
 1. Valve Design: EN13397
 2. Face to face length: EN558 Series 7 (BS5156)
 3. Valve end connections: Flanged to EN1092-2 type 21, PN10 (valves DN65 with 4 holes as accepted variant in standard)
 4. Pressure Tests: EN12266-1
 Rubber Diaphragm - 16bar (DN25-50), 10bar (DN65-125)

10	Spring Pin	1	carbon steel
9	Handwheel	1	DI
8	Pin	2	carbon steel
7	Spindle	1	Stainless Steel
6	Thrust Bearing	1	acetyl plastic
5	Compressor	1	DI
4	Shell	1	DI
3	Diaphragm	1	Natural rubber
2	Lining	1	Natural rubber
1	Body	1	DI
Item No.	Description	Qty	Material

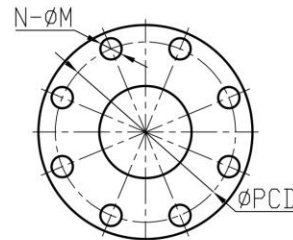

PN10	N	4	4	4	4	8	8
	ØM	14	19	19	19	19	19
	ØPCD	85	110	125	145	160	180
	ØD	117	150	165	185	200	220
h	13	16	17	19	19	19	
f	3	3	3	3	3	3	
L	127	159	190	216	254	305	
H2	112	156	177	213	273	320	
H1	100	136	151	183	198	266	
Size	DN25	DN40	DN50	DN65	DN80	DN100	

Designer				Standardization				Drawing Mark				Weight			
				2023-08-17				S							
Corrector				Authorized				Total				Pages			
				Approved by											

ASSEMBLY DRAWING
WEIR TYPE DIAPHRAGM VALVE
DN25-DN100
BS-GWT35-025-100-00