

Stainless Steel Knife Gate Valve

Viton Seats

Rising Stem

PN10

Standard Specifications

- Design & manufacture to MSS SP-81
- Face to Face conforms to MSS SP-81
- Flange Dimensions to SABS 1123 T1000
- Test & Inspect conform to MSS SP-81

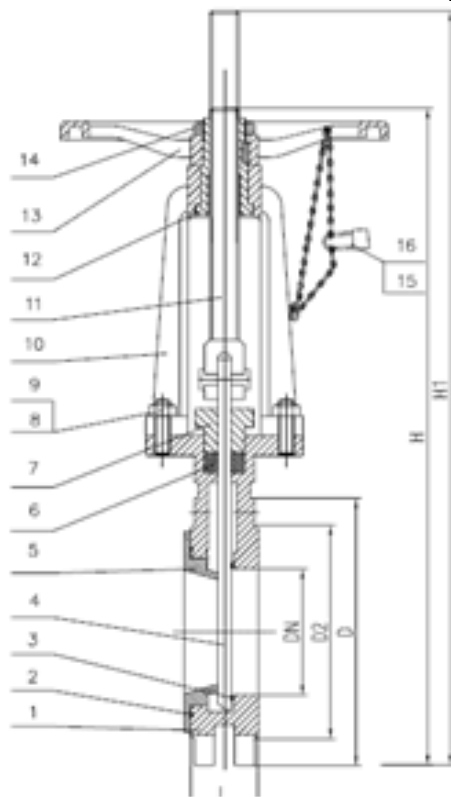

| NO | PART NAME | MATERIAL |
|----|----------------|-----------------|
| 16 | Lock | Carbon Steel |
| 15 | Chain | Carbon Steel |
| 14 | Lock Nut | Carbon Steel |
| 13 | Hand wheel | Malleable Iron |
| 12 | Yoke Nut | Aluminum-bronze |
| 11 | Stem | SS316 |
| 10 | Yoke | A351 CF8M |
| 9 | Nut | Stainless Steel |
| 8 | Bolting | Stainless Steel |
| 7 | Gland | A351 CF8M |
| 6 | Packing | PTFE |
| 5 | Deflector hole | A351 CF8M |
| 4 | Knife | SS316 |
| 3 | Seat ring | Viton |
| 2 | O ring | Viton |
| 1 | Body | A351 CF8M |

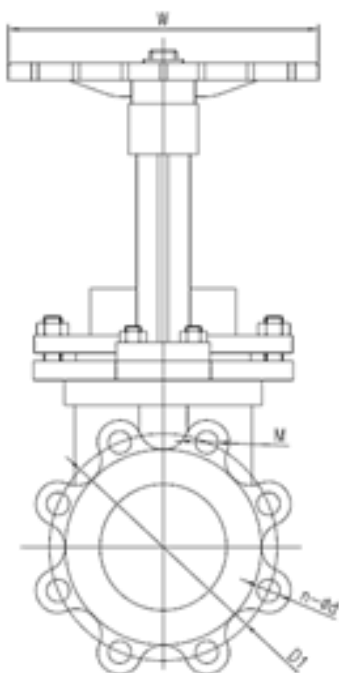

| Size | Main Dimension (mm)PN10 | | | | | | | | | |
|------|-------------------------|-----|--------|-----|-----|------|------|-----|-------------|-------------|
| DN | D1 | D2 | n-ød | M | L | H | H1 | W | Total Width | weight(KGS) |
| 50 | 125 | 102 | 4-ø18 | M16 | 50 | 380 | 430 | 180 | 160 | 9 |
| 80 | 160 | 138 | 8-ø18 | M16 | 50 | 450 | 530 | 200 | 195 | 12 |
| 100 | 180 | 158 | 8-ø18 | M16 | 50 | 497 | 597 | 220 | 215 | 14 |
| 150 | 240 | 212 | 8-ø22 | M20 | 60 | 670 | 720 | 280 | 280 | 25 |
| 200 | 295 | 268 | 8-ø22 | M20 | 60 | 770 | 970 | 300 | 335 | 41 |
| 250 | 350 | 320 | 12-ø22 | M20 | 70 | 915 | 1165 | 350 | 390 | 57 |
| 300 | 400 | 370 | 12-ø22 | M20 | 80 | 1070 | 1370 | 350 | 440 | 71 |
| 350 | 460 | 430 | 16-ø22 | M20 | 90 | 1200 | 1550 | 400 | 500 | 115 |
| 400 | 515 | 482 | 16-ø26 | M24 | 100 | 1330 | 1730 | 450 | 565 | 160 |
| 500 | 620 | 585 | 20-ø26 | M24 | 114 | 1635 | 2135 | 550 | 670 | 240 |
| 600 | 725 | 685 | 20-ø26 | M24 | 120 | 1890 | 2490 | 600 | 780 | 330 |