

# Series 5800

## Electric Actuated Control Pinch Valve



Red Valve Company, Inc.

- ▶ Electric actuation provides precise, accurate control
- ▶ Sleeve is the only wetted part, resulting in constant break away torques
- ▶ Centerline Closure
- ▶ Same face-to-face as gate, plug, or ball valves
- ▶ Bi-directional drop tight shutoff



The Series 5800 Electrically Actuated Control Valve is reliable, maintenance-free, and cost effective. Replacing a plug valve, gate valve, or ball valve is easy with the Series 5800 because it has the same face-to-face dimensions. There are no seats to grind, no stuffing box to repack, and no packing gland to adjust, ever. The rugged, self-cleaning elastomer sleeve isolates all mechanical parts of the mechanism, so the break away torque remains constant.

Red Valve Series 5800 control valve closes the sleeve on centerline and can be actuated with an AUMA, Rotork or other standard motor electric operators. Declutch and override components are furnished as standard. Operators can be furnished as an integral part of the electric operator or with a remote station. Optional features include: heaters, thermostats, explosive-proof construction, position indicators, indication lights, and proportioning control from a 4-20mA instrument signal.

The Series 5800 has the same face-to-face as gate, plug or ball valves, ANSI 16.10 up to 6" sizes. Optional 8", 10", and 12" are available with cone sleeve trims.

### Materials of Construction

- ▶ Cast Iron or Aluminum Bodies
- ▶ Sleeves available in Pure Gum Rubber, Neoprene, Hypalon®, Chlorobutyl, Polyurethane, Buna-N, EPDM and Viton®
- ▶ Cone sleeve trim options available to maximize sleeve life in modulating service
- ▶ Drilled and tapped to mate with ANSI B16.5 Class 125 flanges

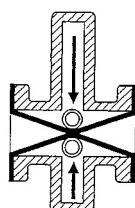

Closed

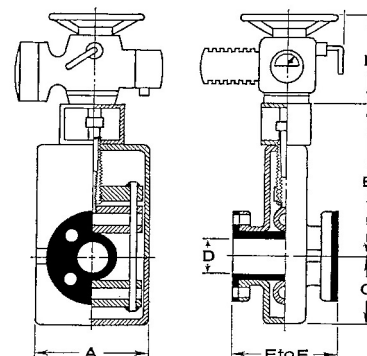

### SERIES 5800

FLANGE SIZE D	LENGTH F to F	WIDTH A	HEIGHT			WORKING PRESSURE psi	WEIGHT (lbs)
			B	C	E		
1"	5-1/2"	4-3/4"	10-3/4"	3"	9-3/4"	100	64
1-1/2"	6-1/2"	6-1/2"	12-5/8"	3-3/4"	9-3/4"	100	86
2"	7"	7-1/2"	13-3/4"	4-1/2"	9-3/4"	100	115
2-1/2"	7-1/2"	8-1/4"	14-1/4"	4-3/4"	9-3/4"	100	127
3"	8"	9-1/2"	15"	5"	10-3/4"	100	216
4"	9"	10-1/2"	15-1/4"	5-1/4"	10-3/4"	100	245
5"	10"	12-1/2"	18-1/2"	6-1/2"	10-3/4"	100	367
6"	10-1/2"	15"	20-1/2"	8"	10-3/4"	100	341
8"	16"	19-1/2"	23"	9"	13-1/2"	55	906
10"	20"	24"	25"	10"	13-1/2"	50	1013
12"	24"	27-1/2"	27"	11"	13-1/2"	50	1128

Dimensions for larger sizes, consult factory.

Control Valves for higher pressure consult factory or reference Red Valve's Series 5200 and 5400 designs.

### SERIES 5800 S

FLANGE SIZE D	LENGTH F to F	WIDTH A	HEIGHT			WORKING PRESSURE psi	WEIGHT (lbs)
			B	C	E		
8"	11-1/2"	19-1/2"	23"	9"	13-1/2"	50	795
10"	13"	24"	25"	10"	13-1/2"	50	890
12"	14"	27-1/2"	27"	11"	13-1/2"	50	995