



Red Valve

Red Valve Company, Inc.®

SERIES RSR Pressure Relief Valve

Installation, Operation, and Maintenance Manual



The Red Valve Series RSR Pressure Relief Valve is a bi-directional valve designed for tough slurry applications. The elastomer sleeve closes on entrapped solids in the line. The flexing action of the sleeve breaks up any sediment or build-up in the valve, which makes the Series RSR a reliable, low maintenance pressure relief valve.

A variety of elastomers are available to suit your specific needs.

- Simple design
- No Packing to maintain, ever
- Cost effective
- No cavities or dead spots to bind valve operation
- Low maintenance

IMPORTANT

Please take a moment to **review this manual**. The improper installation or use of this product may result in personal injury, product failure, or reduced product life. Red Valve Co., Inc. can accept **NO** liability resulting from the improper use or installation of this product. If you have any questions or problems, please call the customer service hotline at (412) 279-8464. We appreciate your comments. And thank you for choosing Red Valve.

GENERAL DESCRIPTION

The Red Valve Series RSR Pressure Relief Valve consists of four major components plus optional accessories:

1. **Body** The body acts as a housing and support for the other valve components. It is not the primary pressure containing component.
2. **Sleeve** The sleeve is the primary pressure containing component and is the only component in contact with the process fluid.
3. **Mechanism** In sizes 3" and under, the pinching mechanism consists of a top pinch bar connected to a sliding stem. In sizes 4" and over, the pinching mechanism consists of a top pinch bar connected to a sliding stem and a bottom pinch bar guided and supported by side rails.
4. **Spring Cylinder** The spring cylinder assembly contains a piston which is connected to a piston rod, which is used to operate the valve. A spring is used to hold the piston to the end of the stroke (valve closed) when the line pressure is less than the cracking pressure.
5. **Accessories**

Limit Switches Limit switches are supplied where required to indicate the valve is open or the valve is closed.

Optional Surge Relief System An oil reservoir is used for controlling surges in the system so that the valve does not slam shut. It is sized to provide enough fluid to the spring cylinder so that the relief valve can achieve a full bore. An adjustable flow control valve is utilized for metering the return of oil into the reservoir. It allows free flow of fluid into the area below the cylinder piston so that the relief valve opens quickly.

Optional Surge Relief System

- | | |
|----------------------------|------------------------|
| 1. Actuator | Valve |
| 2. Oil Reservoir | 4. Extended Yoke |
| 3. Adjustable Flow Control | 5. Oil Resistant Seals |

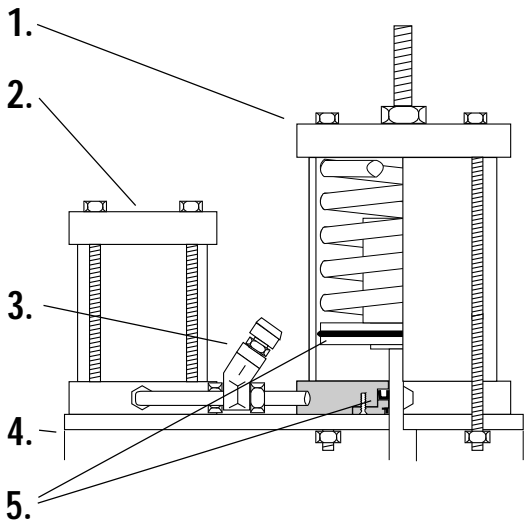

INSTALLATION

1. Series RSR Pressure Relief Valves have standard ANSI B16.1 Class 125 flanges which are equivalent to ANSI B16.5 Class 150 flanges. Due to clearances, the valves have tapped holes instead of through holes. **CAUTION:** Do not use bolts that are too long, as they may bottom out and crack the body. Stud bolts are recommended.
2. The flanges mating to the Series RSR should be serrated approximately 1/16" x 90°. Rubber will creep along smooth metal, PVC, or Teflon flanges, eventually causing a leak. Flange I.D. should match the sleeve I.D. and should be free of sharp edges which could cut into sleeve flanges. Weld neck or socket weld flanges are recommended. Slip on or screw on flanges have a larger I.D. and can cut the rubber sleeve. If slip on or screw on flanges must be used, grind off all sharp I.D. edges.

PARTS – Series RSR 3" and Smaller

- | | |
|-----------------------|----------------------------|
| 1. Actuator | 6. Body Bottom |
| 2. Mounting Bracket | 7. Stroke Adjuster |
| 3. Body Top | 8. Jam Nuts |
| 4. Pinching Mechanism | 9. Pressure Adjusting Stem |
| 5. Sleeve | 10. Jam Nut |

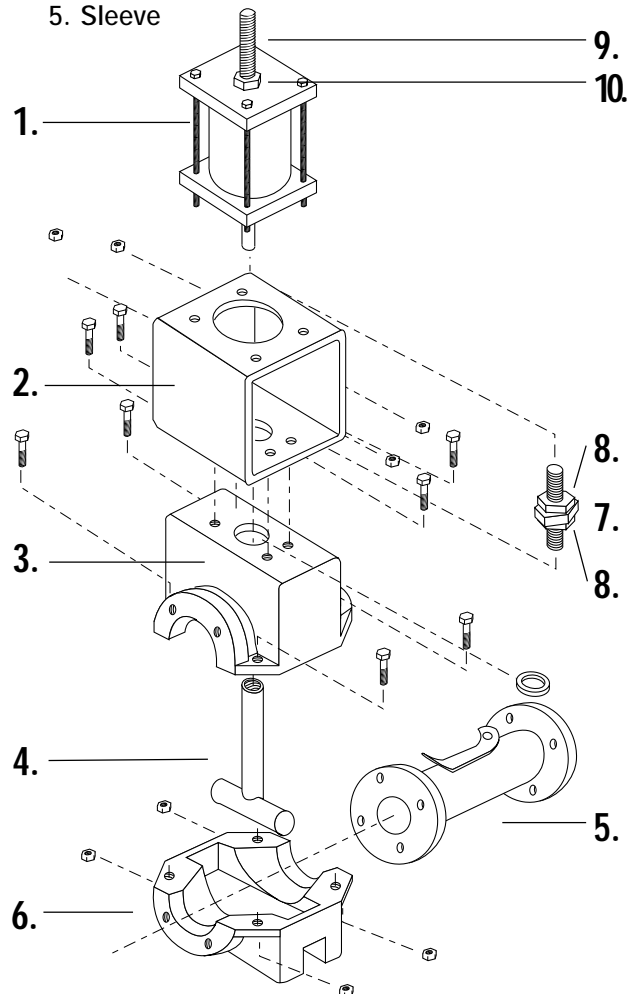

3. Tighten all flange bolts to values listed in the table on the back page. You will not overtorque the flange rubber.
4. If flanges leak during operation, retighten the flange bolts.

OPERATION AND ADJUSTMENT

1. All units are adjusted, inspected, and tested at the factory before shipment. Calibration and stroke adjust-

2. Be certain the valve is closed completely and not cracked open in the closed position.

Operating the valve in a cracked open position can shorten sleeve life, since flow velocities are very high under these conditions. If the valve cannot be closed completely, the valve should be adjusted as follows:

For valves up to 3" in size, use the stem adjuster between the cylinder piston rod and the valve stem. See attached supplemental instructions for details of adjustment.

For valves 4" and larger, the lower pinch bar can be raised by turning the adjusting nuts on the top of the guide rails clockwise. First, loosen the jam nuts, then turn the lower adjusting nut on each side rail one to two turns in the clockwise (tightening) direction. Be sure to turn each nut an equal amount. Check for complete closure of the valve. If necessary, repeat these steps until the valve seals completely. Finally, tighten the jam nuts, being careful not to disturb the setting of the adjusting nuts.

3. Adjust the pressure adjustment stem for the desired cracking pressure. Turning the threaded rod in (clockwise) increases the cracking pressure. Turning the threaded rod out (counter-clockwise) decreases the cracking pressure. If the line pressure cannot be controlled to make the cracking pressure adjustment, the valve will have to be taken out of the line to make the adjustment. If the valve is taken out of the line, make sure to bolt on flanges at both ends of the valve to hold the sleeve in place and get an accurate adjustment.
4. A spare sleeve should be placed on order when this valve is placed in service.
5. A rebuild kit for the cylinder assembly should also be ordered at the time that the valve is placed in service.

PARTS – Series RSR 4" and Larger

- | | |
|-----------------------|-----------------------------|
| 1. Actuator | 6. Body Bottom |
| 2. Mounting Bracket | 7. Stroke Adjuster |
| 3. Body Top | 8. Jam Nuts |
| 4. Pinching Mechanism | 9. Adjusting Nuts |
| 5. Sleeve | 10. Pressure Adjusting Stem |
| | 11. Jam Nut |

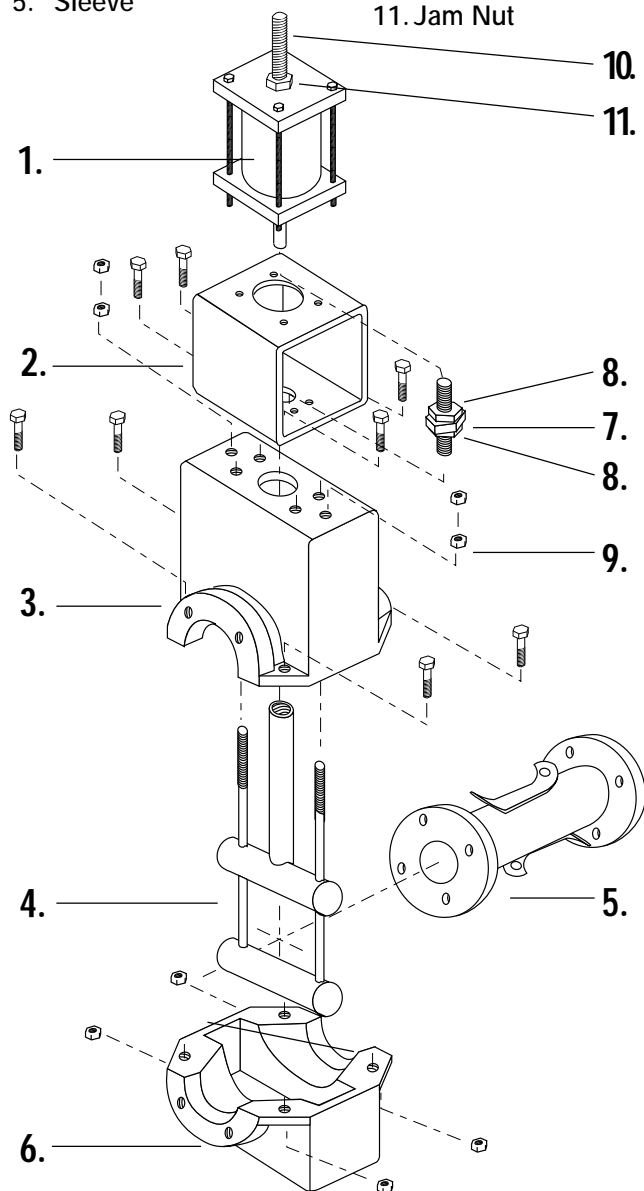

MAINTENANCE

1. **Lubrication** The valve mechanism and actuator were completely lubricated during final assembly and testing at the factory, and do not need to be lubricated at start-up.
2. **Sleeve Replacement**

WARNING: BE SURE TO FLUSH ALL HAZARDOUS MATERIAL AND BLEED ALL PRESSURE FROM THE PIPELINE BEFORE PROCEEDING!

1. Remove the valve from the pipeline.
2. Disassemble the body by removing the body bolts and remove the lower half of the body.
3. Remove the old sleeve by unfastening the positive opening tabs, collapsing one flange, and pulling the sleeve through the mechanism.
4. Slide the new sleeve through the mechanism and repeat the above steps in reverse order. Be sure the

flange bolt holes in the sleeve line up with the bolt holes in the body flange before bolting the two halves together. **Note:** For Cone and Variable Orifice Sleeves, be sure that the sleeve is oriented correctly with the flange marked "Inlet" on the upstream side of the valve, to insure proper operation of the valve.

3. Actuator Removal and Refurbishment

WARNING: SPRING LOADED ACTUATORS MUST BE SERVICED WITH EXTREME CAUTION TO PREVENT INJURY. THE SPRINGS ARE COMPRESSED AND HIGHLY STRESSED. THE TOP CYLINDER HEAD OR OTHER PARTS CAN FLY OFF AND CAUSE SERIOUS INJURY IF THE SPRING COMPRESSION IS NOT RELIEVED PROPERLY.

SPRING CYLINDER

1. The tie rods of spring loaded actuators are extra long to allow the spring compression to be relieved gradually. When disassembling the valve, DO NOT cut off the extra length of thread, even if it has become rusty or bent. This thread is needed to gradually relieve the spring compression.

2. Remove all piping connected to the cylinder.

3. Loosen the jam nut and pressure adjusting stem (counter-clockwise) completely.

4. Remove the four nuts on the tie rods holding the cylinder to the mounting bracket. Separate the valve stem from the piston rod by loosening the jam nuts and unthreading the stem adjuster. Remove the actuator from the valve and mounting bracket.

5. Loosen the tie rods by turning the hex heads on the tie rods counterclockwise. Turn each tie rod only two or three turns and then go to the next one. Continue until all four tie rods have been unthreaded two or three turns. The compressed spring will push the cylinder heads apart, keeping tension on the tie rods.

Continue loosening each of the tie rods two to three turns at a time, so that the cylinder heads remain parallel as they separate. When the tie rods are completely unthreaded, the spring tension will be completely relieved.

6. Remove the piston and piston rod from the assembly. Remove the front bushing and seal from the bottom cylinder head. Clean out the tetra cord gasketing material from the cylinder groove in both cylinder heads. Do not use sharp tools, such as a screwdriver, which may scratch or damage the groove. Remove the O-ring from the groove in the piston.

7. Clean all parts thoroughly, including the inside of the cylinder tubing of any foreign material.

8. Inspect the sliding and sealing surfaces of all parts for nicks, scratches, and signs of wear. Check and inspect the bore of the cylinder for

scratches, excessive wear, and any other defects that might prevent the piston O-ring from sealing properly. Inspect the piston rod for signs of wear, nicks, dents, scratches, or any other condition that may damage the rod bearing or seals. In most cases a little polishing of the various parts will restore them to servicable condition. Excessive wear on one side of a piston rod or rod bearing usually indicates misalignment and should be corrected.

9. Use new tetra cord, seals, and O-rings from the rebuild kit. Lubricate the new seals, O-ring, and inside wall of the cylinder using a silicone based grease. The tetra cord does not need to be lubricated. Reassemble in the reverse order of the above steps. Use care to prevent damage to the O-rings and seals. Tie rod threads should be coated with a high quality anti-seize compound to allow tightening of the tie rods evenly for proper pre-stressing of the spring. Once

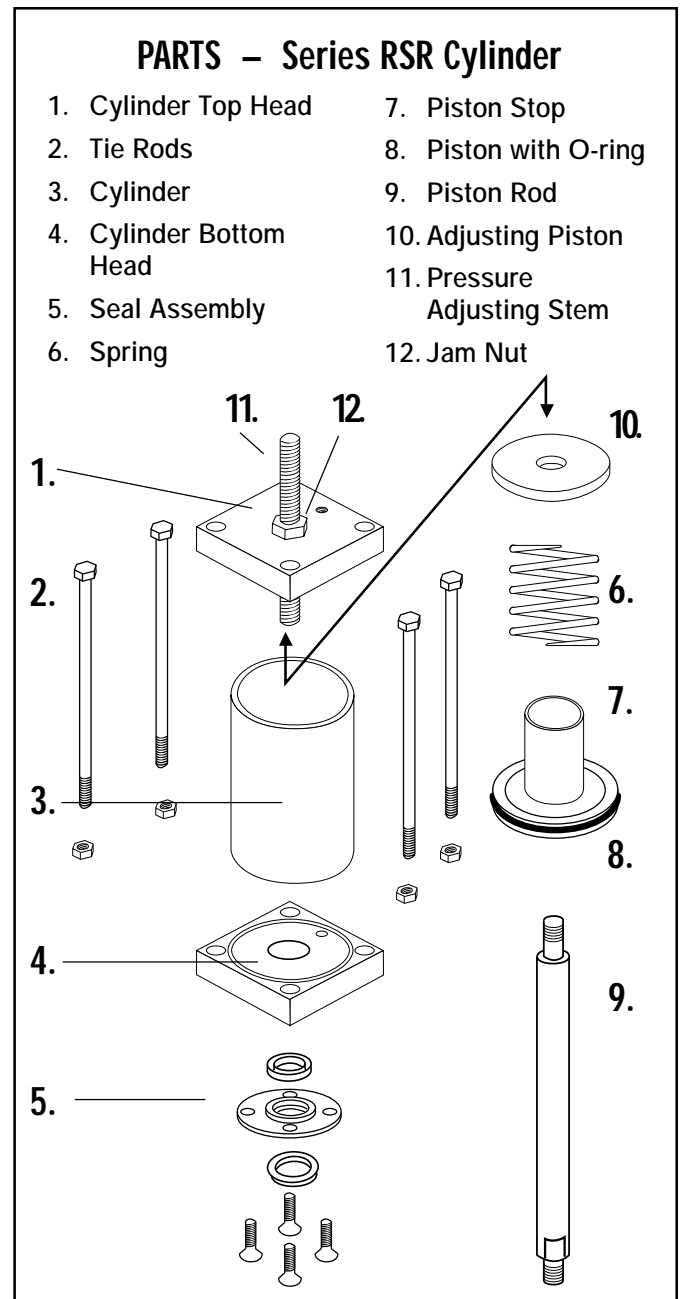

the cylinder heads contact the spring, turn each tie rod only two to three turns before going on to the next one, to keep the cylinder heads parallel while compressing the spring.

10. After the cylinder has been completely reassembled it should be tested, either on a test bench or installed on the valve. Check for rod seal leakage and cylinder head leakage as the piston is cycled.

11. Readjust following instructions in **Operation and Adjustment** section.

MISCELLANEOUS

Reduced Port or Pre-Pinched Valves When replacing either a Reduced Port or Pre-Pinched sleeve in Series RSR Valves, the pinching bars should be spaced at their original setting (Please consult factory for details if this is not clear).

Returns All returns must have standard Red Valve Company return goods tags. Sleeves to be inspected by Red Valve Company must have the tag firmly attached to the sleeve via the bolt holes, and must list the company, order number, address, valve serial number, your telephone number, operating temperature, pressure, closing frequency, fluid media, and total days in service.

STORAGE

If your Series RSR Pressure Relief Valve is to be stored for a period of time prior to installation, the following storage guidelines will help preserve your valve and assure trouble-free installation.

1. Store valve and any spare sleeves in a cool, clean, dry location.
2. Avoid exposure to light, electric motors, dirt, or chemicals. Resilient sleeves are subject to rapid deterioration when exposed to ozones and certain chemicals.
3. Grease stem liberally. Do not stack other items on top of the valve.
4. Store Installation Operation Maintenance Manual with the valve so it will be readily available for installation.

DOUBLE WALL

Double Wall Sleeves have triple life expectancy on severe abrasion. The extra thickness requires the next larger flange size on the valve body.

It is recommended that the sleeve I.D. be the same as the pipe I.D. (Fig. 1) This will require that an oversize mating flange also be installed on the pipe. This is easily done by using blind flanges and boring the I.D. to suit the existing pipe. For example, on a 6" flange, 4" bore Double Wall valve, the mating flange would be a 6" blind flange bored out to slip over the 4" pipe (approximately 4-1/2" diameter).

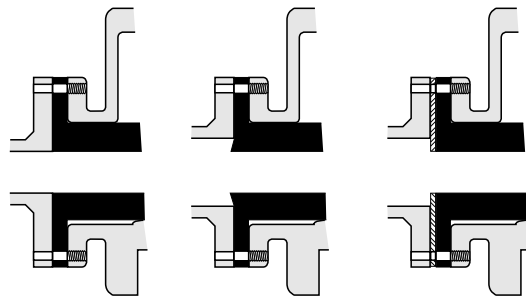

FIG. 1

FIG. 2

FIG. 3

If it is not possible to match the pipe and sleeve I.D. as described above, the flanges will mate and the sleeve I.D. will protrude into the pipeline (Fig. 2). To prevent bulging and premature breaking of the Double Wall Sleeve, a steel washer must be installed as shown (Fig. 3). The steel washer should be 1/8" thick and be serrated. The washer O.D. can be just short of the bolt holes, or it can equal the flange O.D.

SERIES RSR FLANGE BOLTING SPECIFICATIONS

VALVE SIZE	NO. OF BOLTS	BOLT CIRCLE DIAMETER	THREAD SIZE	L	A	B	C	BOLT TORQUE (ft. lbs)
1"	4	3-1/8"	1/2" - 13 NC	1-9/16"	1/2"	1/2"	9/16"	20
1-1/2"	4	3-7/8"	1/2" - 13 NC	1-7/8"	1/2"	11/16"	11/16"	30
2"	4	4-3/4"	5/8" - 11 NC	2"	1/2"	3/4"	3/4"	50
2-1/2"	4	5-1/2"	5/8" - 11 NC	2-1/4"	1/2"	7/8"	7/8"	60
3"	4	6"	5/8" - 11 NC	2-9/16"	3/4"	7/8"	15/16"	70
4"	8	7-1/2"	5/8" - 11 NC	2-11/16"	3/4"	1"	15/16"	50
5"	8	8-1/2"	3/4" - 10 NC	2-5/8"	3/4"	15/16"	15/16"	60
6"	8	9-1/2"	3/4" - 10 NC	3-1/8"	1"	1-1/8"	1"	80
8"	8	11-3/4"	3/4" - 10 NC	3-1/4"	1"	1-1/8"	1-1/8"	90
10"	12	14-1/4"	7/8" - 9 NC	3-3/8"	1"	1"	5/16"	70
12"	12	17"	7/8" - 9 NC	3-1/2"	1"	1-1/4"	1-1/4"	100
14"	12	18-3/4"	1" - 8 NC	3-3/4"	1"	1-3/8"	1-3/8"	100
16"	16	21-1/4"	1" - 8 NC	3-7/8"	1"	1-7/16"	1-7/16"	70
18"	16	22-3/4"	1-1/8" - 7 NC	4-11/16"	1-1/2"	1-5/8"	1-9/16"	90
20"	20	25"	1-1/8" - 7 NC	4-15/16"	1-1/2"	1-3/4"	1-11/16"	90
24"	20	29-1/2"	1-1/4" - 7 NC	5-3/8"	1-1/2"	2"	1-7/8"	110

- Torque values are suggested minimum values.
- Torque all flange bolts in a star pattern. First to 50% of tabulated values, then re-torque to 100% of tabulated values. If greater torque is required, continue re-torquing in increments of 50% of tabulated values.
- Variables such as surface finish on bolt threads, type of anti-seize compound used, and surface finish of the mating flanges all have an effect on the minimum torque required to obtain a leak tight flange seal.
- Use of a high quality anti-seize compound on all bolt threads is recommended.

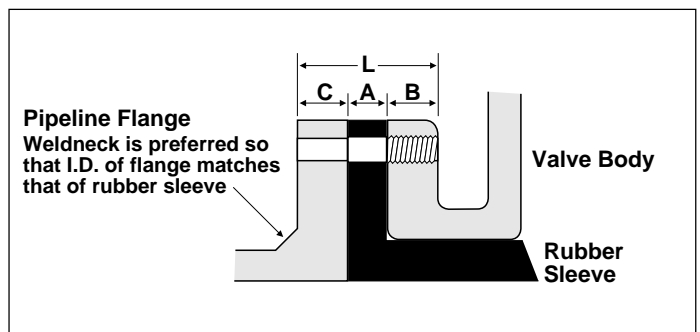

RED VALVE WARRANTY

WARRANTIES - REMEDIES - DISCLAIMERS - LIMITATION OF LIABILITY
 Unless otherwise agreed to in writing signed by Red Valve, all Products supplied by Red Valve will be described in the specifications set forth on the face hereof.

THE WARRANTIES SET FORTH IN THIS PROVISION ARE EXCLUSIVE AND IN LIEU OF ALL OTHER WARRANTIES WHETHER STATUTORY, EXPRESS OR IMPLIED (INCLUDING ALL WARRANTIES OF MERCHANTABILITY AND FITNESS FOR A PARTICULAR PURPOSE AND ALL WARRANTIES ARISING FROM COURSE OF DEALING OR USAGE OR TRADE).

Red Valve Products are guaranteed for a period of one year from date of shipment, against defective workmanship and material only, when properly installed, operated and serviced in accordance with Red Valve's recommendations. Replacement for items of Red Valve's manufacture will be made free of charge if proved to be defective within such year; but not claim for transportation, labor or consequential damages shall be allowed. We shall have the option of requiring the return of the defective product to our factory, with transportation charges prepaid, to establish the claim and our liability shall be limited to the repair or replacement of the defective product, F.O.B. our factory. Red Valve will not assume costs incurred to remove or install defective products nor shall we incur backcharges or liquidated damages as a result of warranty work. Red Valve does not guarantee resistance to corrosion erosion, abrasion or other sources of failure, nor does Red Valve guarantee a minimum length of service, or that the product shall be fit for any particular service. Failure of purchaser to give prompt written notice of any alleged defect under this guarantee forthwith upon its discovery, or use, and possession thereof after an attempt has been made and completed to remedy defects therein, or failure to return product or part for replacement as herein provided, or failure to install and operate said products and parts according to instructions furnished by Red Valve, or failure to pay entire contract price when due, shall be a waiver by purchaser of all rights under these representations. All orders accepted shall be deemed accepted subject to this warranty which shall be exclusive of any other or previous warranty, and shall be the only effective guarantee or warranty binding on Red Valve, anything on the contrary contained in purchaser's order, or represented by any agent or employee of Red Valve in writing or otherwise, notwithstanding implied warranties. RED VALVE MAKES NO WARRANTY THAT THE PRODUCTS, AUXILIARIES AND PARTS ARE MERCHANTABILITY OR FIT FOR ANY PARTICULAR PURPOSE.



700 N. Bell Avenue
 Carnegie, PA 15106
 phone: 412 279-0044
 fax: 412 279-7878

Red Valve Company, Inc.®