

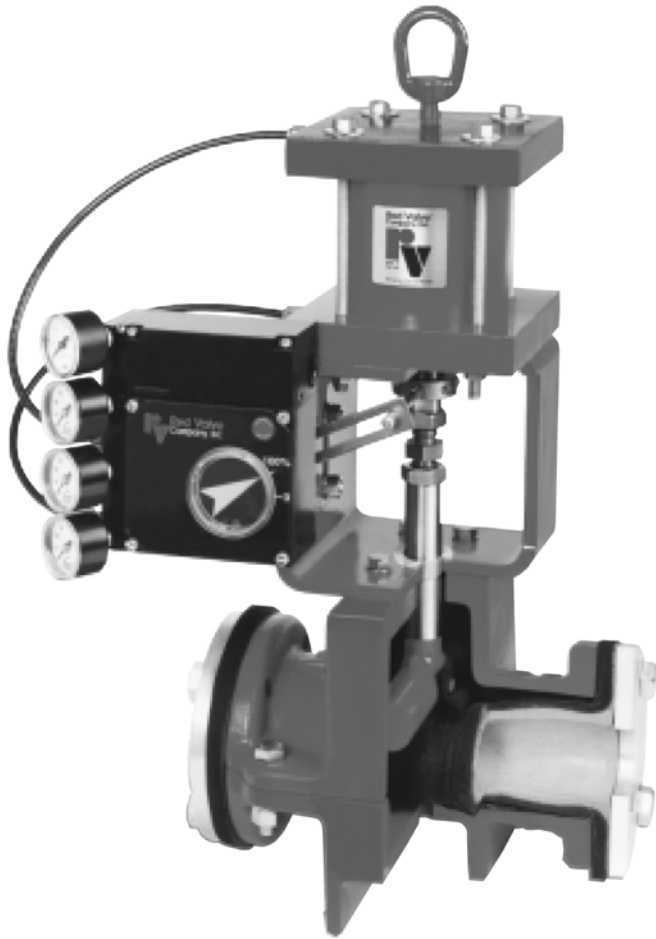

Red Valve Company, Inc.

SERIES 5200 & 5200D

Installation, Operation, and Maintenance Manual



The Red Valve Series 5200 Pneumatically Actuated Control Pinch Valve is a bi-directional valve designed for tough slurry applications. The elastomer sleeve closes on entrapped solids in the line. The flexing action of the sleeve breaks up any sediment or build-up in the valve, which makes the Series 5200 a reliable, low maintenance control valve.

A variety of elastomers are available to suit your specific needs. Along with the standard Red Valve sleeve, we offer Cone, Variable Orifice, Reduced Port, and Double Wall sleeves for special applications.

- Simple design
- No Packing to maintain, ever
- Cost effective
- No cavities or dead spots to bind valve operation
- Low maintenance

IMPORTANT

Please take a moment to **review this manual. Before performing any maintenance on the valve be sure that the pipeline has been depressurized.** The improper installation or use of this product may result in personal injury, product failure, or reduced product life. Red Valve Co., Inc. can accept NO liability resulting from the improper use or installation of this product. If you have any questions or problems, please call the customer service hotline at (412) 279-0044. We appreciate your comments. And thank you for choosing Red Valve.

GENERAL DESCRIPTION

The Red Valve Series 5200 Pneumatically Operated Control Pinch Valve consists of four major components plus optional accessories:

1. **Body** The body acts as a housing and support for the other valve components. It is not the primary pressure containing component.
2. **Sleeve** The sleeve is the primary pressure containing component and is the only component in contact with the process fluid.
3. **Mechanism** In sizes 3" and under, the pinching mechanism consists of a top pinch bar connected to a sliding stem. In sizes 4" and over, the pinching mechanism consists of a top pinch bar connected to a sliding stem and a bottom pinch bar guided and supported by side rails.
4. **Pneumatic Actuator** The pneumatic actuator contains a piston which is connected to a piston rod, which is used to operate the valve. Double acting actuators do not contain a spring. Fail closed and fail open actuators contain a spring to return the piston to the end of the stroke when all air pressure is removed.

5. Accessories

Positioner For modulating applications, the valve is supplied with a positioner that accepts the standard ISA input signals of 4-20 mA or 3-15 psi.

Filter/Regulator The filter/regulator provides clean air at a constant pressure to the positioner and/or actuator, provided the plant air supply pressure does not fall below the regulator set point.

Limit Switches Limit switches are supplied where required to indicate the valve is open or the valve is closed.

Solenoid Valves Solenoid valves are supplied for on-off applications to control the valve from a remote location.

Handwheel Override A handwheel override is supplied when it is necessary to open or close the valve if the control system signal or plant air supply is lost.

Instructions for the installation, operation, and maintenance of these accessories are included as supplements to these instructions, or with the accessory when the accessory is supplied as a separate item.

INSTALLATION

1. Series 5200 Control Valves have standard ANSI B16.1 Class 125 flanges which are equivalent to ANSI B16.5 Class 150 flanges. Due to clearances, the valves have tapped holes instead of through holes. **CAUTION:** Do not use bolts that are too long, as they may bottom out and crack the body. Stud bolts are recommended.
2. The flanges mating to the Series 5200 should be serrated approximately $1/16"$ x 90° . Rubber will creep along smooth metal, PVC, or Teflon flanges, eventually causing a leak. Flange I.D. should match the sleeve I.D. and should be free of sharp edges which could cut into sleeve

flanges. Weld neck or socket weld flanges are recommended. Slip on or screw on flanges have a larger I.D. and can cut the rubber sleeve. If slip on or screw on flanges must be used, grind off all sharp I.D. edges.

3. Do not use sharp tools, such as screwdrivers or crow bars, on the rubber during installation. This can cut and damage the flange face and cause possible leakage.
4. The valve should be completely open before installing the valve in the pipeline or tightening the flange bolts. Valves with Fail Closed spring return cylinders are shipped with the lower portion of the cylinder pressurized to keep the valve completely open during shipment, storage, and installation. See the supplementary instructions covering the installation of valves with fail closed cylinders under the Miscellaneous section of these instructions. Tighten all flange bolts to values listed in the table on the back page. You will not overtorque the flange rubber.

PARTS – Series 5200 3" and Smaller

- | | |
|---------------------|-----------------------|
| 1. Actuator | 4. Pinching Mechanism |
| 2. Mounting Bracket | 5. Sleeve |
| 3. Body Top | 6. Body Bottom |
| | 7. Stroke Adjuster |

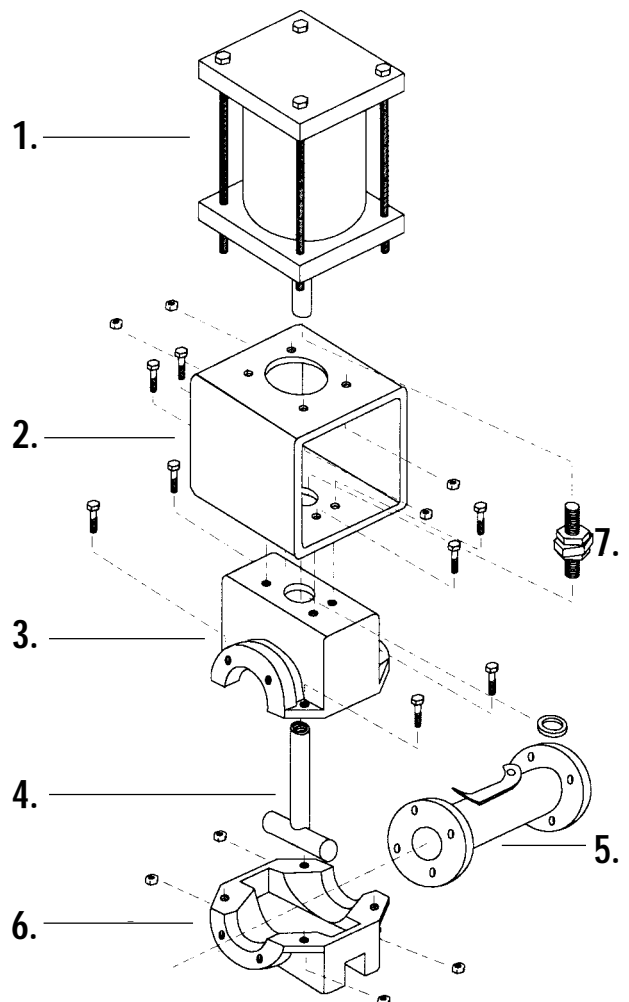

5. If flanges leak during operation, open the valve and retighten the flange bolts. Stroke the valve closed and then reopen and retighten the flange bolts.
6. Connect air lines. Be extra careful installing air lines. On valves with positioners, if plant air is connected to the instrument air port the positioner may be damaged. Read the positioner instructions supplied. A filter/pressure reducing regulator with integral gauge should be placed in the plant air supply line. This will prevent damage to the positioner and actuator from dirt and rust in the supply line as well as overpressures or surges.
7. Connect all electrical wiring to accessories such as solenoid valves and positioners as shown on the individual supplementary sheets included with these instructions or with the accessory.

OPERATION AND ADJUSTMENT

1. All units are adjusted, inspected, and tested at the factory before shipment. Calibration and stroke adjustment may change during shipment. An operational test is recommended before installation in the pipeline.
2. For both on-off and modulating valves, be certain the valve is closed completely and not cracked open in the closed position.

Operating the valve in a cracked open position can shorten sleeve life, since flow velocities are very high under these conditions. If the valve cannot be closed completely, the valve should be adjusted as follows:

For valves up to 3" in size, use the stem adjuster between the cylinder piston rod and the valve stem. See attached supplemental instructions for details of adjustment.

For valves 4" and larger, the lower pinch bar can be raised by turning the adjusting nuts on the top of the guide rails clockwise. First, loosen the jam nuts, then turn the lower adjusting nut on each side rail one to two turns in the clockwise (tightening) direction. Be sure to turn each nut an equal amount. Check for complete closure of the valve. If necessary, repeat these steps until the valve seals completely. Finally, tighten the jam nuts, being careful not to disturb the setting of the adjusting nuts.

3. A spare sleeve should be placed on order when this valve is placed in service.
4. A rebuild kit for the cylinder assembly should also be ordered at the time that the valve is placed in service.

MAINTENANCE

1. **Lubrication** The valve mechanism and actuator were completely lubricated during final assembly and testing at the factory, and do not need to be lubricated at start-up.

2. Sleeve Replacement

WARNING: BE SURE TO FLUSH ALL HAZARDOUS MATERIAL AND BLEED ALL PRESSURE FROM THE PIPELINE BEFORE PROCEEDING!

1. Open the valve completely.
 2. Remove the valve from the pipeline.
 3. Disassemble the body by removing the body bolts and remove the lower half of the body.
 4. Remove the old sleeve by unfastening the positive opening tabs, collapsing one flange, and pulling the sleeve through the mechanism.
 5. Slide the new sleeve through the mechanism and repeat the above steps in reverse order. Be sure the flange bolt holes in the sleeve line up with the bolt holes in the body flange before bolting the two halves together.
- Note:** For Cone and Variable Orifice Sleeves, be sure that the sleeve is oriented correctly with the flange marked "Inlet" on the upstream side of the valve, to insure proper operation of the valve.

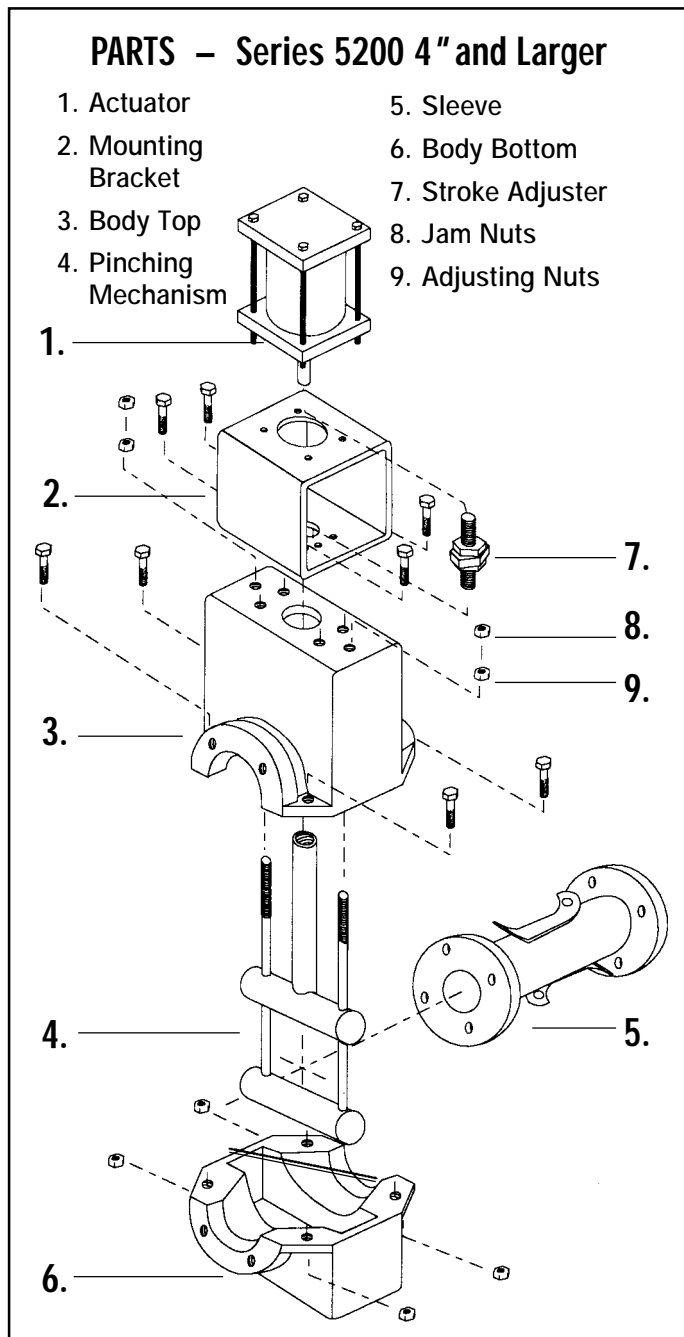

3. Actuator Removal and Refurbishment

WARNING: SPRING LOADED ACTUATORS MUST BE SERVICED WITH EXTREME CAUTION TO PREVENT INJURY. THE SPRINGS ARE COMPRESSED AND HIGHLY STRESSED. THE TOP CYLINDER HEAD OR OTHER PARTS CAN FLY OFF AND CAUSE SERIOUS INJURY IF THE SPRING COMPRESSION IS NOT RELIEVED PROPERLY.

SPRING LOADED ACTUATORS

1. The tie rods of spring loaded actuators are extra long to allow the spring compression to be relieved gradually. When disassembling the valve, DO NOT cut off the extra length of thread, even if it has become rusty or bent. This thread is needed to gradually relieve the spring compression.
2. Remove all piping connected to the cylinder and remove all accessory arms connected to the valve stem or piston rod.
3. Remove the four nuts on the tie rods holding the cylinder to the mounting bracket. Separate the valve stem from the piston rod by loosening the jam nuts and unthreading the stem adjuster. Remove the actuator from the valve and mounting bracket.
4. Loosen the tie rods by turning the hex heads on the tie rods counterclockwise. Turn each tie rod only two or three turns and then go to the next one. Continue until all four tie rods have been unthreaded two or three turns. The compressed spring will push the cylinder heads apart, keeping tension on the tie rods.

Continue loosening each of the tie rods two to three turns at a time, so that the cylinder heads remain parallel as they separate. When the tie rods are completely unthreaded, the spring tension will be completely relieved.

5. Remove the piston and piston rod from the assembly. Remove the front bushing and seal from the bottom cylinder head. Clean out the tetra cord gasket material from the cylinder groove in both cylinder heads. Do not use sharp tools, such as a screwdriver, which may scratch or damage the groove. Remove the O-ring from the groove in the piston.

6. Clean all parts thoroughly, including the inside of the cylinder tubing of any foreign material.

7. Inspect the sliding and sealing surfaces of all parts for nicks, scratches, and signs of wear. Check and inspect the bore of the cylinder for scratches, excessive wear, and any other defects that might prevent the piston O-ring from sealing properly. Inspect the piston rod for signs of wear, nicks, dents, scratches, or any other condition that may damage the rod bearing or seals. In most cases a little polishing of the various parts will restore them to serviceable condition. Excessive wear on one side of a piston rod or rod bearing usually indicates misalignment and should be corrected.

8. Use new tetra cord, seals, and O-rings from the rebuild kit. Lubricate the new seals, O-ring, and inside wall of the cylinder using a silicone based grease. The tetra cord does not need to be lubricated. Reassemble in the reverse order of the above steps. Use care to prevent damage to the O-rings and seals. Tie rod threads should be coated with a high quality anti-seize compound to allow tightening of the tie rods evenly for proper pre-stressing of the spring. Once the cylinder heads contact the spring, turn each tie rod only two to three turns before going on to the next one, to keep the cylinder heads parallel while compressing the spring.
9. After the cylinder has been completely reassembled it should be tested, either on a test bench or installed on the valve. Check for rod seal leakage and cylinder head leakage as the piston is cycled at operating pressure.

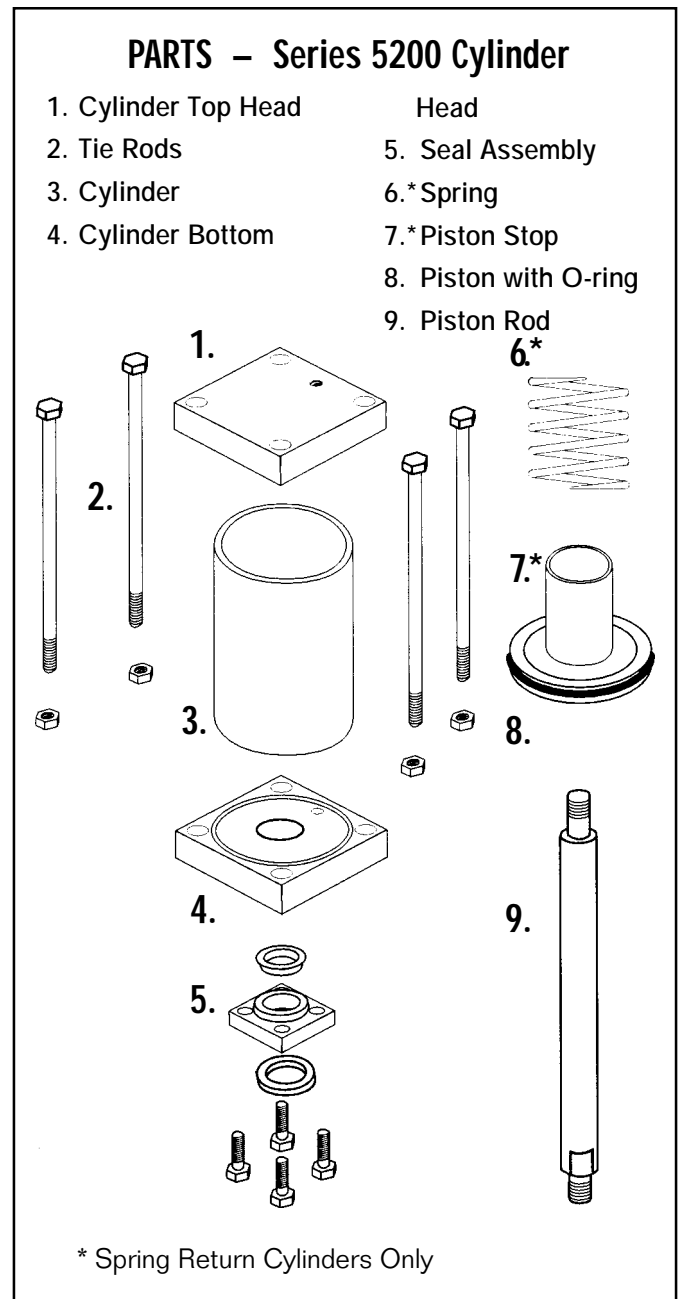

DOUBLE ACTING CYLINDERS

1. Disassembly, refurbishment, reassembly, and testing of double acting cylinders follows the same procedure as for spring loaded cylinders above, except that the tie rods are not extra long and there is no spring to relieve or recompress.

MISCELLANEOUS

FAIL CLOSE CYLINDERS

1. Series 5200 Control Valves with fail close cylinders use a spring to pinch the sleeve closed when there is no air pressure in the cylinder. In order to prevent distorting the rubber flanges during shipment and before the valve is installed in the pipeline, the lower portion of the cylinder is charged with up to 150 psi air pressure. Do not relieve this pressure before installing the valve.
2. After installing the valve in the pipeline, slowly bleed the air from the lower portion of the cylinder. This should be done by slowly opening the ball valve installed at the lower cylinder head of the actuator. After all the air has been bled from the cylinder, remove the ball valve and retain for possible future use.
3. After removing the ball valve, install the air line from the positioner or solenoid valve to the lower cylinder head.

Reduced Port or Pre-Pinched Valves When replacing either a Reduced Port or Pre-Pinched sleeve in Series 5200 Valves, the pinching bars should be spaced at their original setting (Please consult factory for details if this is not clear).

Returns All returns must have standard Red Valve Company return goods tags. Sleeves to be inspected by Red Valve Company must have the tag firmly attached to the sleeve via the bolt holes, and must list the company, order number, address, valve serial number, your telephone number, operating temperature, pressure, closing frequency, fluid media, and total days in service.

STORAGE

If your Series 5200 Control Pinch Valve is to be stored for a period of time prior to installation, the following storage guidelines will help preserve your valve and assure trouble-free installation.

1. Store valve and any spare sleeves in a cool, clean, dry location.
2. Avoid exposure to light, electric motors, dirt, or chemicals. Resilient sleeves are subject to rapid deterioration when exposed to ozones and certain chemicals.
3. Grease stem liberally and store valve in the full open position. Do not stack other items on top of the valve.
4. Store Installation Operation Maintenance Manual with the valve so it will be readily available for installation.

DOUBLE WALL

Double Wall Sleeves have triple life expectancy on severe abrasion. The extra thickness requires the next larger flange size on the valve body.

It is recommended that the sleeve I.D. be the same as the pipe I.D. (Fig. 1) This will require that an oversize mating flange also be installed on the pipe. This is easily done by using blind flanges and boring the I.D. to suit the existing pipe. For example, on a 6" flange, 4" bore Double Wall valve, the mating flange would be a 6" blind flange bored out to slip over the

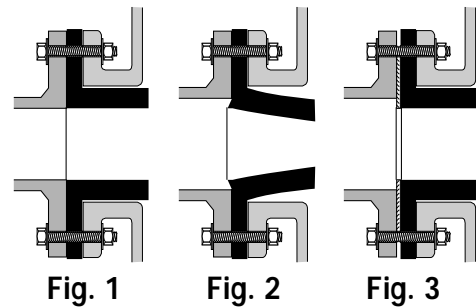

4" pipe (approximately 4-1/2" diameter).

If it is not possible to match the pipe and sleeve I.D. as described above, the flanges will mate and the sleeve I.D. will protrude into the pipeline (Fig. 2). To prevent bulging and premature breaking of the Double Wall Sleeve, a steel washer must be installed as shown (Fig. 3). The steel washer should be 1/8" thick and be serrated. The washer O.D. can be just short of the bolt holes, or it can equal the flange O.D. and bolt holes can be drilled through the washer.

SERIES 5200 FLANGE BOLTING SPECIFICATIONS

| VALVE SIZE | NO. OF BOLTS | BOLT CIRCLE DIAMETER | THREAD SIZE | A | B | BOLT TORQUE (ft. lbs) |
|------------|--------------|----------------------|---------------|--------|---------|-----------------------|
| 1" | 4 | 3-1/8" | 1/2" - 13 NC | 1/2" | 3/4" | 20 |
| 1-1/2" | 4 | 3-7/8" | 1/2" - 13 NC | 1/2" | 5/8" | 25 |
| 2" | 4 | 4-3/4" | 5/8" - 11 NC | 1/2" | 3/4" | 40 |
| 2-1/2" | 4 | 5-1/2" | 5/8" - 11 NC | 1/2" | 3/4" | 50 |
| 3" | 4 | 6" | 5/8" - 11 NC | 1/2" | 3/4" | 55 |
| 4" | 8 | 7-1/2" | 5/8" - 11 NC | 3/8" | 7/8" | 40 |
| 5" | 8 | 8-1/2" | 3/4" - 10 NC | 3/8" | -" | 50 |
| 6" | 8 | 9-1/2" | 3/4" - 10 NC | 5/8" | 7/8" | 60 |
| 8" | 8 | 11-3/4" | 3/4" - 10 NC | 1" | 1" | 70 |
| 10" | 12 | 14-1/4" | 7/8" - 9 NC | 1/2" | 1" | 70 |
| 12" | 12 | 17" | 7/8" - 9 NC | 5/8" | 1-1/4" | 75 |
| 14" | 12 | 18-3/4" | 1" - 8 NC | 1" | 1-3/8" | 100 |
| 16" | 16 | 21-1/4" | 1" - 8 NC | 1" | 1-7/16" | 70 |
| 18" | 16 | 22-3/4" | 1-1/8" - 7 NC | 1-1/2" | 1-5/8" | 55 |
| 20" | 20 | 25" | 1-1/8" - 7 NC | 1-1/2" | 1-3/4" | 50 |
| 24" | 20 | 29-1/2" | 1-1/4" - 7 NC | 1-1/2" | 2" | 70 |

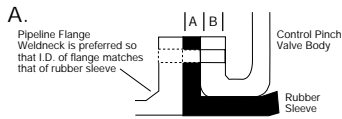

A. Standard pinch valves are built to schedule 40 pipe I.D. and to ANSI Class 125/150# flange and bolt circle specifications. It is recommended that the mating flanges are flat and full faced.

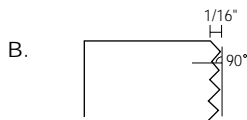

B. It is recommended that the mating flange be serrated to "grip" the rubber flange. The serrations should be cut 1/16" deep, with a 90° angle tool point. The pitch should be 8 (eight) cuts per inch.

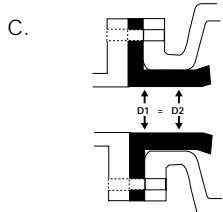

C. Mating flange ID must match the pinch valve sleeve ID.

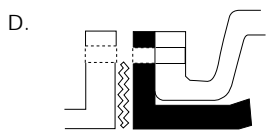

D. When installing a pinch valve to a rubber, PVC, or any "slick" mating flange, we recommend that you install a metal serrated gasket between the two flanges to assist in the seal.

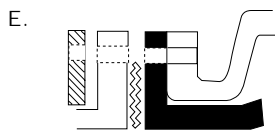

E. When bolting a pinch valve to a PVC or synthetic mating flange, use a split back-up retaining ring, since the mating flange will yield prior to generating enough force on the flange faces for a proper seal.

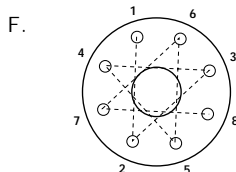

F. Torque all the flange bolts in a star pattern, first to 50% of tabulated valves, then retorque to 100% of tabulated valves. If greater torque is required, continue retorquing in increments of 50% of tabulated valves. Use of high quality anti-seize compound on all bolt threads is recommended.

Variables such as the surface finish on bolt threads, type of anti-seize compound used, and surface finish of the mating flanges all have an effect on the minimum torque required to obtain a leak-tight flange seal.

RED VALVE WARRANTY

WARRANTIES - REMEDIES - DISCLAIMERS - LIMITATION OF LIABILITY
Unless otherwise agreed to in writing signed by Red Valve, all Products supplied by Red Valve will be described in the specifications set forth on the face hereof.

THE WARRANTIES SET FORTH IN THIS PROVISION ARE EXCLUSIVE AND IN LIEU OF ALL OTHER WARRANTIES WHETHER STATUTORY, EXPRESS OR IMPLIED (INCLUDING ALL WARRANTIES OF MERCHANTABILITY AND FITNESS FOR A PARTICULAR PURPOSE AND ALL WARRANTIES ARISING FROM COURSE OF DEALING OR USAGE OR TRADE).

Red Valve Products are guaranteed for a period of one year from date of shipment, against defective workmanship and material only, when properly installed, operated and serviced in accordance with Red Valve's recommendations. Replacement for items of Red Valve's manufacture will be made free of charge if proved to be defective within such year; but not claim for transportation, labor or consequential damages shall be allowed. We shall have the option of requiring the return of the defective product to our factory, with transportation charges prepaid, to establish the claim and our liability shall be limited to the repair or replacement of the defective product, F.O.B. our factory. Red Valve will not assume costs incurred to remove or install defective products nor shall we incur backcharges or liquidated damages as a result of warranty work. Red Valve does not guarantee resistance to corrosion erosion, abrasion or other sources of failure, nor does Red Valve guarantee a minimum length of service, or that the product shall be fit for any particular service. Failure of purchaser to give prompt written notice of any alleged defect under this guarantee forthwith upon its discovery, or use, and possession thereof after an attempt has been made and completed to remedy defects therein, or failure to return product or part for replacement as herein provided, or failure to install and operate said products and parts according to instructions furnished by Red Valve, or failure to pay entire contract price when due, shall be a waiver by purchaser of all rights under these representations. All orders accepted shall be deemed accepted subject to this warranty which shall be exclusive of any other or previous warranty, and shall be the only effective guarantee or warranty binding on Red Valve, anything on the contrary contained in purchaser's order, or represented by any agent or employee of Red Valve in writing or otherwise, notwithstanding implied warranties. RED VALVE MAKES NO WARRANTY THAT THE PRODUCTS, AUXILIARIES AND PARTS ARE MERCHANTABILITY OR FIT FOR ANY PARTICULAR PURPOSE.

SERIES 5200D IOM SUPPLEMENT

Sleeve Installation / Replacement

Install the replacement sleeve in accordance with the instructions one page three: Maintenance and Sleeve Replacement.

Preparation

- Lower the bottom pinch bar by turning the adjusting nuts on the guide rails on both sides of the valve. Make sure the bottom pinch bar clears the sleeve.
- Turn the stroke adjuster to shorten the length of the piston rod/valve stem.
- Raise the upper pinch bar by applying air pressure to the inlet port on the bottom cylinder head to retract the piston rod.
- For leak testing, you must mount a blind flange to the inlet end of the valve. The flange needs to be drilled and tapped to accept a pressure fitting.
- Mount a weld neck or slip-on flange weld neck to the outlet end of the valve.

Adjustment of Lower Pinch Bar and Valve Pre-Pinch

With the valve sitting vertically, raise the lower pinch bar by loosening the top jamb nuts on the guide rails, and turning the lower nuts to extend the guide rails further out of the valve body. NOTE: The two guide rails should extend an equal amount. Raise the lower pinch bar until the lower part of the sleeve just starts to deflect. This "base" position will indicate that the lower pinch bar is in contact with the sleeve. Now, continue to raise the lower pinch bar until 30% of the sleeve inlet bore diameter has been closed. For example, a 10" valve needs to have the lower pinch bar raised 3 inches. This pre-pinch can be accomplished by turning the guide bar nuts until the guide bars extend an additional 3" from the "base" position. Tighten the upper jamb nuts.

Adjustment of Upper Pinch Bar and Valve Stroke

Close the valve by applying air pressure to the inlet port of the top cylinder head. If you observe a gap between the top of the sleeve and the bottom of the sleeve, turn the stroke adjustment to increase to piston rod length. Continue to observe the gap between the top and bottom of the sleeve until is closed completely. If the gap is larger on one side than the other, turn the adjustment nut on the guide rail nearest the gap to raise the lower pinch bar. NOTE: It is important that the upper and lower pinch bars are parallel to obtain a proper seal. Once the gap is visibly closed, turn the stem adjustment nut one additional full turn to properly seat the valve.

Testing

With a blind flange mounted to the inlet flange of the valve, and a weld-neck flange mounted to the outlet flange of the valve, apply appropriate plant air pressure to the cylinder to close the valve. Apply test pressure to the blind flange on the inlet side of the valve that is equal to the maximum shutoff pressure of the valve. Look for leaks at the weld neck flange end of the valve. If the leak is on one side or the other, turn the adjustment nut on the guide rail nearest the leak to raise the lower pinch bar. If the leak is in the center or on both sides, turn the stroke adjuster to lengthen the piston rod/valve stem. Continue adjusting until the leak stops. Tighten the jamb nuts on the stroke adjuster and guide rails. Remove blind flange and weld-neck flange.

Installation

To align the flange holes of the sleeve with the mating flange, it may be necessary to lower the bottom pinch bar. Before loosening the jamb nuts and lowering the pinch bar, record the position of the side rail threads. After installation, return the bottom pinch bar to the marked position to maintain the proper pre-pinch on the sleeve. Re-tighten the jamb nuts.

