

## 3-Piece Ball Valve Stainless Steel

1000psi Threaded BSP

Lever Operated



### Standard Specifications

- Design & manufacture to ANSI B16.34
- Adjustable packing gland
- Bottom-loaded Blow-out proof stem
- Inspection & Testing to API 598
- Ends Threaded BSP

Main Technical Parameter			
Normal pressure		1000	PSi
Test pressure	Shell test pressure	10.5	MPa
	Tightness test	7.7	
	Gas-Tightness test	0.6	
Max working temperature		-20~150	°C
Applicable medium: water, gas, oil, acid			

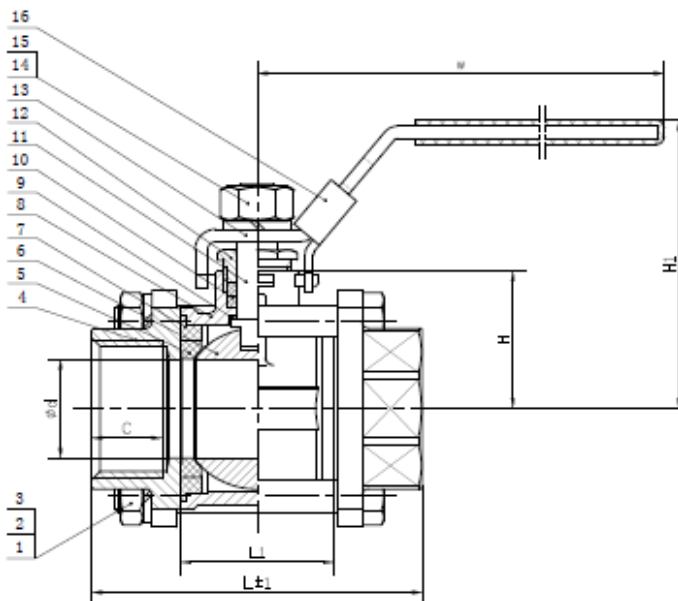

SIZE	DN	Ød	L	H	H1	W	C	L1	Weight kg	Torque Nm
¼	6	10.5	60	25	58	98	12	22	0.38	4.2
½	10	12	60	25	58	98	12	22	0.41	4.2
¾	15	14	60	26	59	98	13.5	25	0.55	7.0
1	20	20	70	30.5	67	120	14	32	0.70	9.0
1 ¼	25	24	80	33.5	70	120	17	37	1.02	12.4
1 ½	32	32	92	41	80.5	150	18	45	1.57	15
2	40	38	107	50	94	170	20	54	2.31	20
2 ½	50	48	125	58	102	170	22	66	3.42	30
3	65	64	160	72.5	125	250	29	84	9.15	42
4	80	76	180	83	135.5	250	29.5	100	12.78	65
5	100	98	225	105	165.5	300	33	128	19.60	100

16	Handle lock	A276 201	A276 201
15	Handle nut	A194-8	A194-8
14	Spring washer	A193-B8	A193-B8
13	Handle	A276 201	A276 201
12	Packing gland	A276 304	A276 304
11	Stem	A276 304	A276 316
10	Packing	PTFE	PTFE
9	Stem gasket	PTFE	PTFE
8	Body	A351 CF8	A351 CF8M
7	Gasket	PTFE	PTFE
6	Ball	SS304	SS316
5	Seat	PTFE/RPTFE	PTFE/RPTFE
4	End cap	A351 CF8	A351 CF8M
3	Nut	A194-8	A194-8
2	Spring washer	A193-B8	A193-B8
1	Bolt	A193-B8	A193-B8
No.	Parts name	Material	